

## MKT RADIAL LACQUERED CAPACITORS (Dipped Type) - Orange

Pitch 5.0/7.5mm

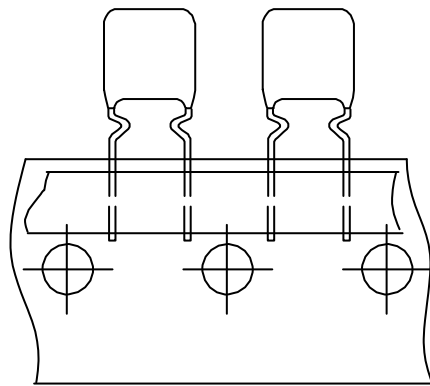

365

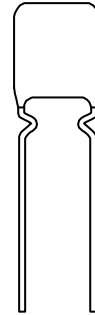

366



367

## QUICK REFERENCE DATA

Capacitance range (E12 series)	0.001 to 1.0 $\mu\text{F}$
Capacitance tolerance	$\pm 10\%$ , $\pm 5\%$
Rated voltage $V_{\text{Rdc}}$	63 V, 100 V, 250 V, 400 V, 630V
Rated voltage $V_{\text{Rac}}$	40 V, 63 V, 160 V, 220 V, 250V
Climatic category	55/105/56
Temperature range	$-55^{\circ}\text{C}$ ~ $+105^{\circ}\text{C}$
Reference specification	IEC 60384-2
Performance grade	Grade 1 (long life)
Coating material	Qualified in accordance with UL94V-0



# a2zelectronic.com

Sourcing Simplified



FEATURES	APPLICATIONS
<ul style="list-style-type: none"><li>. Low inductive wound cell of metallized (PETP) film</li><li>. Cell protected by epoxy lacquer</li><li>. Radial leads of tin coated wire</li><li>. Withstand to solvents and rinsing liquids</li></ul>	<ul style="list-style-type: none"><li>. Blocking and coupling</li><li>. Bypass and energy reservoir application</li></ul>

- Please refer to caution and warning at <http://www.pilkor.co.kr/download/Introductions.pdf> before using these products.



# a2zelectronic.com

Sourcing Simplified



Ordering Information

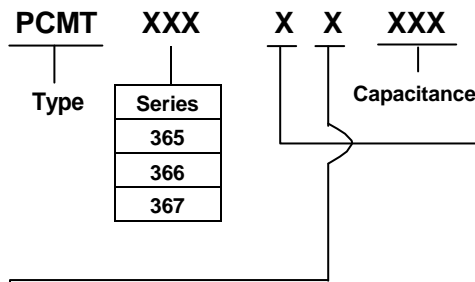
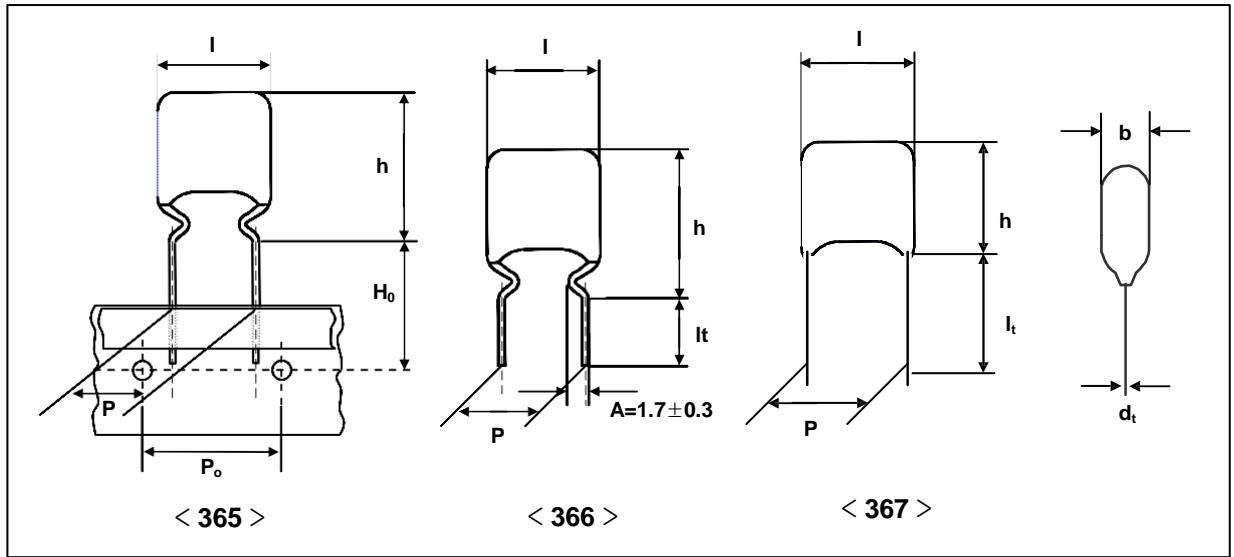

Series
365
366
367

Code	I <sub>max</sub>	Voltage
1	10.0	63V
2		100V
4		250V
5		400V
6	7.5	630V
7		63V
8		100V

Available versions						Product(I <sub>max</sub> )	
Series	Code	Packing Method	C-tol.	Lead length & Height	Hole to hole (P <sub>0</sub> )	7.5	10.0
						Pitch (P)	
365	1	Taped on reel	±10%	H <sub>0</sub> = 16mm	12.7mm	5.08	5.08
	2	Taped on reel	± 5%	H <sub>0</sub> = 16mm	12.7mm	5.08	5.08
	5	Ammopack	±10%	H <sub>0</sub> = 16mm	12.7mm	5.08	5.08
	6	Ammopack	± 5%	H <sub>0</sub> = 16mm	12.7mm	5.08	5.08
366	1	Loose in box	±10%	lt = 17±4mm	-	5.08	7.62
	2	Loose in box	± 5%	lt = 17±4mm	-	5.08	7.62
	5	Loose in box	±10%	lt = 4+1/-0.5mm	-	5.08	7.62
	6	Loose in box	± 5%	lt = 4+1/-0.5mm	-	5.08	7.62
367	1	Loose in box	±10%	lt = 22±4mm	-	5.08	7.62
	2	Loose in box	± 5%	lt = 22±4mm	-	5.08	7.62
	5	Loose in box	±10%	lt = 4+1/-0.5mm	-	5.08	7.62
	6	Loose in box	± 5%	lt = 4+1/-0.5mm	-	5.08	7.62

Sourcing Simplified



367



a2zelectronic.com

Sourcing Simplified



## Packing Information

SERIES	SMALLEST PACKAGING QUANTITIES (SPQ)	reel	ammopack
	DIMENSIONS	SPQ	SPQ
365	3.5 x 12.5 x 7.5	1500	1500
	4.0 x 13.0 x 7.5	1500	1500
	4.5 x 13.5 x 7.5	1000	1000
	5.0 x 14.0 x 7.5	1000	1000
	5.5 x 14.5 x 7.5	1000	1000
	6.0 x 15.0 x 7.5	1000	1000
	6.0 x 15.5 x 7.5	1000	1000
	4.0 x 13.5 x 10.0	1500	1500
	4.0 x 15.0 x 10.0	1500	1500
	4.5 x 14.0 x 10.0	1000	1000
	4.5 x 14.0 x 10.5	1000	1000
	4.5 x 15.5 x 10.0	1000	1000
	5.0 x 14.5 x 10.0	1000	1000
	5.0 x 14.5 x 10.5	1000	1000
	5.0 x 16.0 x 10.0	1000	1000
	5.5 x 15.0 x 10.0	1000	1000
	5.5 x 15.0 x 10.5	1000	1000
	5.5 x 16.5 x 10.0	1000	1000
	6.0 x 15.5 x 10.0	1000	1000
	6.0 x 15.5 x 10.5	1000	1000
6.0 x 16.5 x 10.0	1000	1000	
6.5 x 17.0 x 10.0	1000	1000	

SERIES	SMALLEST PACKAGING QUANTITIES (SPQ)	It = 17 ± 4mm	It = 4+1/-0.5mm
	DIMENSIONS	SPQ	SPQ
366	All dimensions	1000	1000



# a2zelectronic.com

Sourcing Simplified



SERIES	SMALLEST PACKAGING QUANTITIES (SPQ)	It = 22 ± 4mm	It = 4+1/-0.5mm
	DIMENSIONS	SPQ	SPQ
367	All dimensions	1000	1000



# a2zelectronic.com

Sourcing Simplified



# Metallized Polyester film capacitors

PCMT 365

 $V_{Rdc} = 63 V$  $V_{Rac} = 40 V$ 

taped versions

Cap ( $\mu F$ )	$b_{max} \times h_{max} \times l_{max}$ (mm)	mass (g)	CATALOGUE NUMBER PCMT 365 .....			
			taped on reel		ammopack	
			H = 16 mm		H = 16 mm	
			C-tol. $\pm 10\%$	C-tol. $\pm 5\%$	C-tol. $\pm 10\%$	C-tol. $\pm 5\%$
Pitch = 5.08 $\pm$ 0.3 mm			dt = 0.5 mm ( + 0.05 / - 0.05 )			
0.047	3.5 x 12.5 x 7.5	0.3	71473	72473	75473	76473
0.056			71563	72563	75563	76563
0.068			71683	72683	75683	76683
0.082			71823	72823	75823	76823
0.1			71104	72104	75104	76104
0.12			71124	72124	75124	76124
0.15	4.0 x 13.0 x 7.5	0.3	71154	72154	75154	76154
0.18	4.5 x 13.5 x 7.5	0.3	71184	72184	75184	76184
0.22			71224	72224	75224	76224
0.27	5.0 x 14.0 x 7.5	0.4	71274	72274	75274	76274
0.33	5.5 x 14.5 x 7.5	0.4	71334	72334	75334	76334
0.39			71394	72394	75394	76394
0.47	6.0 x 15.5 x 7.5	0.4	71474	72474	75474	76474
0.56	5.5 x 14.0 x 7.5	0.4	71564	72564	75564	76564
0.68	5.5 x 14.5 x 7.5	0.4	71684	72684	75684	76684
0.82	6.0 x 15.0 x 7.5	0.5	71824	72824	75824	76824
1.0	6.0 x 15.5 x 7.5	0.5	71105	72105	75105	76105

## SPECIFIC REFERENCE DATA FOR THE 63V DC CAPACITORS

Description	Value		
	at 1kHz	at 10kHz	at 100kHz
Tangent of loss angle (unit : $10^{-4}$ )			
$C \leq 0.1 \mu F$	$\leq 75$	$\leq 130$	$\leq 225$
$0.1 \mu F \square C \leq 0.47 \mu F$	$\leq 75$	$\leq 130$	$\leq 300$
$0.47 \mu F \square C \leq 1.0 \mu F$	$\leq 75$	$\leq 130$	-
Rated voltage pulse slope (dV/dt) <sub>R</sub> at 63V (DC)	110 V/ $\mu s$		
R between leads at 10V , for $C \leq 0.33 \mu F$	$\square 15\ 000\ M\Omega$		
RC between leads at 10V, for $C \square 0.33 \mu F$	$\square 5\ 000\ s$		
R between interconnected leads and casing; 100V ; 1min	$\square 30\ 000\ M\Omega$		



**a2zelectronic.com**  
Sourcing Simplified



**Metallized Polyester  
film capacitors**

**PCMT 365**

Withstanding voltage DC (cut off current 10mA) ;rise time  
100 V/s

100V ; 1min



**a2zelectronic.com**

Sourcing Simplified





# Metallized Polyester film capacitors

PCMT 365

 $V_{Rdc} = 100\text{ V}$  $V_{Rac} = 63\text{ V}$ 

taped versions

Cap ( $\mu\text{F}$ )	$b_{\text{max}} \times h_{\text{max}} \times l_{\text{max}}$ (mm)	mass (g)	CATALOGUE NUMBER			
			PCMT 365 .....			
			taped on reel		ammopack	
			H = 16 mm		H = 16 mm	
			C-tol. $\pm 10\%$	C-tol. $\pm 5\%$	C-tol. $\pm 10\%$	C-tol. $\pm 5\%$
Pitch = 5.08 $\pm$ 0.3 mm			dt = 0.5 mm ( + 0.05 / - 0.05 )			
0.01	3.5 x 12.5 x 7.5	0.3	81103	82103	85103	86103
0.012			81123	82123	85123	86123
0.015			81153	82153	85153	86153
0.018			81183	82183	85183	86183
0.022			81223	82223	85223	86223
0.027			81273	82273	85273	86273
0.033			81333	82333	85333	86333
0.039			81393	82393	85393	86393
0.047			81473	82473	85473	86473
0.056			81563	82563	85563	86563
0.068			81683	82683	85683	86683
0.082			4.0 x 13.0 x 7.5	0.3	81823	82823
0.1	81104	82104			85104	86104

## SPECIFIC REFERENCE DATA FOR THE 100V DC CAPACITORS

Description	Value		
	at 1kHz	at 10kHz	at 100kHz
Tangent of loss angle (unit : $10^{-4}$ ) $C \leq 0.1\mu\text{F}$	$\leq 75$	$\leq 130$	$\leq 225$
$0.1\mu\text{F} \square C \leq 0.27\mu\text{F}$	$\leq 75$	$\leq 130$	$\leq 300$
Rated voltage pulse slope $(dV/dt)_R$ at 100V (DC)	110 V/ $\mu\text{s}$		
R between leads at 100V, for $C \leq 0.33\mu\text{F}$	$\square 15\ 000\ \text{M}\Omega$		
R between interconnected leads and casing; 100V ; 1min	$\square 30\ 000\ \text{M}\Omega$		
Withstanding voltage DC (cut off current 10mA) ; rise time 100 V/s	160V ; 1min		



# a2zelectronic.com

Sourcing Simplified



# Metallized Polyester film capacitors

PCMT 365

 $V_{Rdc} = 63 V$  $V_{Rac} = 40 V$ 

taped versions

Cap ( $\mu F$ )	$b_{max} \times h_{max} \times l_{max}$ (mm)	mass (g)	CATALOGUE NUMBER			
			PCMT 365 .....			
			taped on reel		ammopack	
			H = 16 mm		H = 16 mm	
		C-tol. $\pm 10\%$	C-tol. $\pm 5\%$	C-tol. $\pm 10\%$	C-tol. $\pm 5\%$	
Pitch = 5.08 $\pm$ 0.3 mm			dt = 0.5 mm ( + 0.05 / - 0.05 )			
0.12	4.0 x 13.5 x 10.0	0.4	11124	12124	15124	16124
0.15			11154	12154	15154	16154
0.18			11184	12184	15184	16184
0.22			11224	12224	15224	16224
0.27	4.5 x 14.0 x 10.0	0.5	11274	12274	15274	16274
0.33	5.0 x 14.5 x 10.0	0.6	11334	12334	15334	16334
0.39			11394	12394	15394	16394
0.47	5.5 x 15.0 x 10.0	0.7	11474	12474	15474	16474
0.56			11564	12564	15564	16564
0.68			11684	12684	15684	16684
0.82			11824	12824	15824	16824
1.0			11105	12105	15105	16105

## SPECIFIC REFERENCE DATA FOR THE 63V DC CAPACITORS

Description	Value		
Tangent of loss angle (unit : $10^{-4}$ )	at 1kHz	at 10kHz	at 100kHz
$C \leq 0.1 \mu F$	$\leq 75$	$\leq 130$	$\leq 225$
$0.1 \mu F \square C \leq 0.47 \mu F$	$\leq 75$	$\leq 130$	$\leq 300$
$0.47 \mu F \square C \leq 1.0 \mu F$	$\leq 75$	$\leq 130$	-
Rated voltage pulse slope $(dV/dt)_R$ at 63V (DC)	18 V/ $\mu s$		
R between leads at 10V, for $C \leq 0.33 \mu F$	$\square 15\ 000\ M\Omega$		
RC between leads at 10V, for $C \square 0.33 \mu F$	$\boxplus 5\ 000\ s$		
R between interconnected leads and casing; 100V ; 1min	$\square 30\ 000\ M\Omega$		
Withstanding voltage DC (cut off current 10mA) ; rise time 100 V/s	100V ; 1min		



# a2zelectronic.com

Sourcing Simplified



# Metallized Polyester film capacitors

PCMT 365

 $V_{Rdc} = 100\text{ V}$  $V_{Rac} = 63\text{ V}$ 

taped versions

Cap ( $\mu\text{F}$ )	$b_{\text{max}} \times h_{\text{max}} \times l_{\text{max}}$ (mm)	mass (g)	CATALOGUE NUMBER			
			PCMT 365 .....			
			taped on reel H = 16 mm		ammopack H = 16 mm	
			C-tol. $\pm 10\%$	C-tol. $\pm 5\%$	C-tol. $\pm 10\%$	C-tol. $\pm 5\%$
Pitch = 5.08 $\pm$ 0.3 mm      dt = 0.5 mm ( + 0.05 / - 0.05 )						
0.039	4.0 x 13.5 x 10.0	0.4	21393	22393	25393	26393
0.047			21473	22473	25473	26473
0.056			21563	22563	25563	26563
0.068			21683	22683	25683	26683
0.082			21823	22823	25823	26823
0.1			21104	22104	25104	26104
0.12	4.5 x 14.0 x 10.5	0.5	21124	22124	25124	26124
0.15	5.0 x 14.5 x 10.5	0.6	21154	22154	25154	26154
0.18			21184	22184	25184	26184
0.22	5.5 x 15.0 x 10.5	0.7	21224	22224	25224	26224
0.27	6.0 x 15.5 x 10.5	0.7	21274	22274	25274	26274
0.33			21334	22334	25334	26334
0.39			21394	22394	25394	26394
0.47			21474	22474	25474	26474

## SPECIFIC REFERENCE DATA FOR THE 100V DC CAPACITORS

Description	Value		
	at 1kHz	at 10kHz	at 100kHz
Tangent of loss angle (unit : $10^{-4}$ ) $C \leq 0.1\mu\text{F}$	$\leq 75$	$\leq 130$	$\leq 225$
$0.1\mu\text{F} \square C \leq 0.47\mu\text{F}$	$\leq 75$	$\leq 130$	$\leq 300$
Rated voltage pulse slope (dV/dt) <sub>R</sub> at 100V (DC)	36 V/ $\mu\text{s}$		
R between leads at 100V, for $C \leq 0.33\mu\text{F}$	$\square 15\ 000\ \text{M}\Omega$		
RC between leads at 100V, for $C \square 0.33\mu\text{F}$	$\boxplus 5\ 000\ \text{s}$		
R between interconnected leads and casing; 100V ; 1min	$\square 30\ 000\ \text{M}\Omega$		
Withstanding voltage DC (cut off current 10mA) ; rise time 100 V/s	160V ; 1min		



# a2zelectronic.com

Sourcing Simplified



# Metallized Polyester film capacitors

PCMT 365

 $V_{Rdc} = 250\text{ V}$  $V_{Rac} = 160\text{ V}$ 

taped versions

Cap ( $\mu\text{F}$ )	$b_{\text{max}} \times h_{\text{max}} \times l_{\text{max}}$ (mm)	mass (g)	CATALOGUE NUMBER			
			PCMT 365 .....			
			taped on reel		ammopack	
			H = 16 mm		H = 16 mm	
			C-tol. $\pm 10\%$	C-tol. $\pm 5\%$	C-tol. $\pm 10\%$	C-tol. $\pm 5\%$
Pitch = 5.08 $\pm$ 0.3 mm      dt = 0.5 mm ( + 0.05 / - 0.05 )						
0.018	4.0 x 13.5 x 10.0	0.4	41183	42183	45183	46183
0.022			41223	42223	45223	46223
0.027			41273	42273	45273	46273
0.033			41333	42333	45333	46333
0.039			41393	42393	45393	46393
0.047			41473	42473	45473	46473
0.056			41563	42563	45563	46563
0.068			41683	42683	45683	46683
0.082			5.0 x 14.5 x 10.5	0.4	41823	42823
0.1	41104	42104			45104	46104
0.12	5.5 x 15.0 x 10.5	0.6	41124	42124	45124	46124
0.15	5.5 x 15.5 x 10.5	0.7	41154	42154	45154	46154

## SPECIFIC REFERENCE DATA FOR THE 250V DC CAPACITORS

Description	Value		
	at 1kHz	at 10kHz	at 100kHz
Tangent of loss angle (unit : $10^{-4}$ ) $C \leq 0.1\mu\text{F}$	$\leq 75$	$\leq 130$	$\leq 225$
$0.1\mu\text{F} \square C \leq 0.47\mu\text{F}$	$\leq 75$	$\leq 130$	$\leq 300$
Rated voltage pulse slope $(dV/dt)_R$ at 250V (DC)	70 V/ $\mu\text{s}$		
R between leads at 100V, for $C \leq 0.33\mu\text{F}$	$\square 30\ 000\ \text{M}\Omega$		
R between interconnected leads and casing; 100V ; 1min	$\square 30\ 000\ \text{M}\Omega$		
Withstanding voltage DC (cut off current 10mA) ; rise time 100 V/s	400V ; 1min		



# a2zelectronic.com

Sourcing Simplified



# Metallized Polyester film capacitors

PCMT 365

 $V_{Rdc} = 400\text{ V}$  $V_{Rac} = 220\text{ V}$ 

taped versions

Cap ( $\mu\text{F}$ )	$b_{\text{max}} \times h_{\text{max}} \times l_{\text{max}}$ (mm)	mass (g)	CATALOGUE NUMBER			
			PCMT 365 .....			
			taped on reel		ammopack	
			H = 16 mm		H = 16 mm	
			C-tol. $\pm 10\%$	C-tol. $\pm 5\%$	C-tol. $\pm 10\%$	C-tol. $\pm 5\%$
Pitch = 5.08 $\pm$ 0.3 mm      dt = 0.5 mm ( + 0.05 / - 0.05 )						
0.010	4.0 x 13.5 x 10.0	0.4	51103	52103	55103	56103
0.012			51123	52123	55123	56123
0.015			51153	52153	55153	56153
0.018	4.0 x 15.0 x 10.0	0.4	51183	52183	55183	56183
0.022	4.5 x 15.5 x 10.0	0.4	51223	52223	55223	56223
0.027	5.0 x 16.0 x 10.0	0.4	51273	52273	55273	56273
0.033	5.5 x 16.5 x 10.0	0.4	51333	52333	55333	56333
0.039	6.0 x 16.5 x 10.0	0.4	51393	52393	55393	56393
0.047	6.5 x 17.0 x 10.0	0.4	51473	52473	55473	56473
0.056			51563	52563	55563	56563

## SPECIFIC REFERENCE DATA FOR THE 400V DC CAPACITORS

Description	Value		
	at 1kHz	at 10kHz	at 100kHz
Tangent of loss angle (unit : $10^{-4}$ ) $C \leq 0.1\mu\text{F}$	$\leq 75$	$\leq 130$	$\leq 225$
Rated voltage pulse slope $(dV/dt)_R$ at 400V (DC)	110 V/ $\mu\text{s}$		
R between leads at 100V, for $C \leq 0.33\mu\text{F}$	$\square 30\ 000\ \text{M}\Omega$		
R between interconnected leads and casing; 100V ; 1min	$\square 30\ 000\ \text{M}\Omega$		
Withstanding voltage DC ( cut off current 10mA ) ; rise time 100 V/s	640V ; 1min		



# a2zelectronic.com

Sourcing Simplified



# Metallized Polyester film capacitors

PCMT 365

 $V_{Rdc} = 630 V$  $V_{Rac} = 250 V$ 

taped versions

Cap ( $\mu F$ )	$b_{max} \times h_{max} \times l_{max}$ (mm)	mass (g)	CATALOGUE NUMBER			
			PCMT 365 .....			
			taped on reel		ammopack	
			H = 16 mm		H = 16 mm	
			C-tol. $\pm 10\%$	C-tol. $\pm 5\%$	C-tol. $\pm 10\%$	C-tol. $\pm 5\%$
Pitch = 5.08 $\pm$ 0.3 mm			dt = 0.5 mm ( + 0.05 / - 0.05 )			
0.010	5.0 x 14.5 x 10.0	0.4	61103	62103	65103	66103
0.012	5.5 x 15.0 x 10.0	0.4	61123	62123	65123	66123
0.015	6.0 x 15.5 x 10.0	0.5	61153	62153	65153	66153

## SPECIFIC REFERENCE DATA FOR THE 630V DC CAPACITORS

Description	Value		
	at 1kHz	at 10kHz	at 100kHz
Tangent of loss angle (unit : $10^{-4}$ ) $C \leq 0.1 \mu F$	$\leq 75$	$\leq 130$	$\leq 225$
Rated voltage pulse slope $(dV/dt)_R$ at 630V (DC)	110 V/ $\mu s$		
R between leads at 100V, for $C \leq 0.33 \mu F$	$\square 30\ 000\ M\Omega$		
R between interconnected leads and casing; 100V ; 1min	$\square 30\ 000\ M\Omega$		
Withstanding voltage DC ( cut off current 10mA ) ; rise time 100 V/s	1008V ; 1min		

# Metallized Polyester film capacitors

PCMT 366

 $V_{Rdc} = 63 V$  $V_{Rac} = 40 V$ 

loose in box

Cap ( $\mu F$ )	$b_{max} \times h_{max} \times l_{max}$ (mm)	mass (g)	CATALOGUE NUMBER PCMT 366 .....			
			loose in box			
			It = 17 $\pm$ 4 mm		It = 4 +1/-0.5 mm	
			C-tol. $\pm 10\%$	C-tol. $\pm 5\%$	C-tol. $\pm 10\%$	C-tol. $\pm 5\%$
Pitch = 5.08 $\pm$ 0.3 mm			dt = 0.5 mm ( + 0.05 / - 0.05 )			
0.047	3.5 x 12.5 x 7.5	0.3	71473	72473	75473	76473
0.056			71563	72563	75563	76563
0.068			71683	72683	75683	76683
0.082			71823	72823	75823	76823
0.1			71104	72104	75104	76104
0.12			71124	72124	75124	76124
0.15	4.0 x 13.0 x 7.5	0.3	71154	72154	75154	76154
0.18	4.5 x 13.5 x 7.5	0.3	71184	72184	75184	76184
0.22			71224	72224	75224	76224
0.27	5.0 x 14.0 x 7.5	0.4	71274	72274	75274	76274
0.33	5.5 x 14.5 x 7.5	0.4	71334	72334	75334	76334
0.39			71394	72394	75394	76394
0.47	6.0 x 15.5 x 7.5	0.4	71474	72474	75474	76474
0.56	5.5 x 14.0 x 7.5	0.4	71564	72564	75564	76564
0.68	5.5 x 14.5 x 7.5	0.4	71684	72684	75684	76684
0.82	6.0 x 15.0 x 7.5	0.5	71824	72824	75824	76824
1.0	6.5 x 15.5 x 7.5	0.5	71105	72105	75105	76105

## SPECIFIC REFERENCE DATA FOR THE 63V DC CAPACITORS

Description	Value		
	at 1kHz	at 10kHz	at 100kHz
Tangent of loss angle (unit : $10^{-4}$ )			
$C \leq 0.1 \mu F$	$\leq 75$	$\leq 130$	$\leq 225$
$0.1 \mu F \square C \leq 0.47 \mu F$	$\leq 75$	$\leq 130$	$\leq 300$
$0.47 \mu F \square C \leq 1.0 \mu F$	$\leq 75$	$\leq 130$	-
Rated voltage pulse slope(dV/dt) <sub>R</sub> at 63V (DC)	110 V/ $\mu s$		
R between leads at 10V , for $C \leq 0.33 \mu F$	$\square 15\ 000\ M\Omega$		
RC between leads at 10V, for $C \square 0.33 \mu F$	$\square 5\ 000\ s$		
R between interconnected leads and casing;100V ; 1min	$\square 30\ 000\ M\Omega$		
Withstanding voltage DC (cut off current 10mA) ;rise time 100 V/s	100V ; 1min		

# Metallized Polyester film capacitors

PCMT 366

 $V_{Rdc} = 100 V$  $V_{Rac} = 63 V \sim$ 

loose in box

Cap ( $\mu F$ )	$b_{max} \times h_{max} \times l_{max}$ (mm)	mass (g)	CATALOGUE NUMBER			
			PCMT 366 .....			
			loose in box			
			lt = 17 $\pm$ 4 mm		lt = 4 +1/-0.5 mm	
			C-tol. $\pm 10\%$	C-tol. $\pm 5\%$	C-tol. $\pm 10\%$	C-tol. $\pm 5\%$
Pitch = 5.08 $\pm$ 0.3 mm      dt = 0.5 mm ( + 0.05 / - 0.05 )						
0.01	3.5 x 12.5 x 7.5	0.3	81103	82103	85103	86103
0.012			81123	82123	85123	86123
0.015			81153	82153	85153	86153
0.018			81183	82183	85183	86183
0.022			81223	82223	85223	86223
0.027			81273	82273	85273	86273
0.033			81333	82333	85333	86333
0.039			81393	82393	85393	86393
0.047			81473	82473	85473	86473
0.056			81563	82563	85563	86563
0.068			81683	82683	85683	86683
0.082	4.0 x 13.0 x 7.5	0.3	81823	82823	85823	86823
0.1			81104	82104	85104	86104

## SPECIFIC REFERENCE DATA FOR THE 100V DC CAPACITORS

Description	Value		
	at 1kHz	at 10kHz	at 100kHz
Tangent of loss angle (unit : $10^{-4}$ ) $C \leq 0.1 \mu F$ $0.1 \mu F \square C \leq 0.27 \mu F$	$\leq 75$ $\leq 75$	$\leq 130$ $\leq 130$	$\leq 225$ $\leq 300$
Rated voltage pulse slope(dV/dt) <sub>R</sub> at 100V (DC)	110 V/ $\mu s$		
R between leads at 100V, for $C \leq 0.33 \mu F$	$\square 15\ 000\ M\Omega$		
R between interconnected leads and casing;100V ; 1min	$\square 30\ 000\ M\Omega$		
Withstanding voltage DC (cut off current 10mA) ;rise time 100 V/s	160V ; 1min		



# Metallized Polyester film capacitors

PCMT 366

 $V_{Rdc} = 63 V$  $V_{Rac} = 40 V$ 

loose in box

Cap ( $\mu F$ )	$b_{max} \times h_{max} \times l_{max}$ (mm)	mass (g)	CATALOGUE NUMBER			
			PCMT 366 .....			
			loose in box			
			It = 17 $\pm$ 4 mm		It = 4 +1/-0.5 mm	
			C-tol. $\pm 10\%$	C-tol. $\pm 5\%$	C-tol. $\pm 10\%$	C-tol. $\pm 5\%$
Pitch = 7.62 $\pm$ 0.3 mm			dt = 0.5 mm ( + 0.05 / - 0.05 )			
0.12	4.0 x 12.0 x 10.0	0.4	11124	12124	15124	16124
0.15			11154	12154	15154	16154
0.18			11184	12184	15184	16184
0.22			11224	12224	15224	16224
0.27	4.5 x 13.0 x 10.5	0.5	11274	12274	15274	16274
0.33	5.0 x 13.5 x 10.5	0.6	11334	12334	15334	16334
0.39			11394	12394	15394	16394
0.47	5.5 x 14.0 x 10.5	0.7	11474	12474	15474	16474
0.56	5.5 x 14.5 x 10.5	0.8	11564	12564	15564	16564
0.68			11684	12684	15684	16684
0.82			11824	12824	15824	16824
1.0			11105	12105	15105	16105

## SPECIFIC REFERENCE DATA FOR THE 63V DC CAPACITORS

Description	Value		
	at 1kHz	at 10kHz	at 100kHz
Tangent of loss angle (unit : $10^{-4}$ )			
$C \leq 0.1 \mu F$	$\leq 75$	$\leq 130$	$\leq 225$
$0.1 \mu F \square C \leq 0.47 \mu F$	$\leq 75$	$\leq 130$	$\leq 300$
$0.47 \mu F \square C \leq 1.0 \mu F$	$\leq 75$	$\leq 130$	-
Rated voltage pulse slope(dV/dt) <sub>R</sub> at 63V (DC)	18 V/ $\mu s$		
R between leads at 10V , for $C \leq 0.33 \mu F$	$\square 15\ 000\ M\Omega$		
RC between leads at 10V, for $C \square 0.33 \mu F$	$\boxplus 5\ 000\ s$		
R between interconnected leads and casing;100V ; 1min	$\square 30\ 000\ M\Omega$		
Withstanding voltage DC (cut off current 10mA) ;rise time 100 V/s	100V ; 1min		

# Metallized Polyester film capacitors

PCMT 366

 $V_{Rdc} = 100\text{ V}$  $V_{Rac} = 63\text{ V}$ 

loose in box

Cap ( $\mu\text{F}$ )	$b_{\text{max}} \times h_{\text{max}} \times l_{\text{max}}$ (mm)	mass (g)	CATALOGUE NUMBER PCMT 366 .....			
			loose in box			
			lt = 17 $\pm$ 4 mm		lt = 4 +1/-0.5 mm	
			C-tol. $\pm 10\%$	C-tol. $\pm 5\%$	C-tol. $\pm 10\%$	C-tol. $\pm 5\%$
Pitch = 7.62 $\pm$ 0.3 mm      dt = 0.5 mm ( + 0.05 / - 0.05 )						
0.039	4.0 x 12.0 x 10	0.4	21393	22393	25393	26393
0.047			21473	22473	25473	26473
0.056			21563	22563	25563	26563
0.068			21683	22683	25683	26683
0.082			21823	22823	25823	26823
0.10	4.0 x 13.0 x 10.0	0.4	21104	22104	25104	26104
0.12	4.5 x 13.0 x 10.5	0.5	21124	22124	25124	26124
0.15	5.0 x 13.0 x 10.5	0.5	21154	22154	25154	26154
0.18	5.0 x 13.5 x 10.5	0.6	21184	22184	25184	26184
0.22	5.5 x 13.5 x 10.5	0.7	21224	22224	25224	26224
0.27	6.0 x 14.5 x 10.5	0.7	21274	22274	25274	26274
0.33	6.0 x 15.0 x 10.5	0.7	21334	22334	25334	26334
0.39			21394	22394	25394	26394
0.47			21474	22474	25474	26474

## SPECIFIC REFERENCE DATA FOR THE 100V DC CAPACITORS

Description	Value		
	at 1kHz	at 10kHz	at 100kHz
Tangent of loss angle (unit : $10^{-4}$ ) $C \leq 0.1\mu\text{F}$	$\leq 75$	$\leq 130$	$\leq 225$
$0.1\mu\text{F} \square C \leq 0.47\mu\text{F}$	$\leq 75$	$\leq 130$	$\leq 300$
Rated voltage pulse slope $(dV/dt)_R$ at 100V (DC)	36 V/ $\mu\text{s}$		
R between leads at 100V, for $C \leq 0.33\mu\text{F}$	$\square 15\ 000\ \text{M}\Omega$		
RC between leads at 100V, for $C \square 0.33\mu\text{F}$	$\boxplus 5\ 000\ \text{s}$		
R between interconnected leads and casing; 100V ; 1min	$\square 30\ 000\ \text{M}\Omega$		
Withstanding voltage DC (cut off current 10mA) ; rise time 100 V/s	160V ; 1min		

# Metallized Polyester film capacitors

PCMT 366

 $V_{Rdc} = 250 V$  $V_{Rac} = 160 V \sim$ 

loose in box

Cap ( $\mu F$ )	$b_{max} \times h_{max} \times l_{max}$ (mm)	mass (g)	CATALOGUE NUMBER				
			PCMT 366 .....				
			loose in box				
			It = 17 $\pm$ 4 mm		It = 4 +/-0.5 mm		
C-tol. $\pm 10\%$		C-tol. $\pm 5\%$		C-tol. $\pm 10\%$		C-tol. $\pm 5\%$	
Pitch = 7.62 $\pm$ 0.3 mm      dt = 0.5 mm ( + 0.05 / - 0.05 )							
0.018	4.0 x 13.0 x 10.0	0.4	41183	42183	45183	46183	
0.022			41223	42223	45223	46223	
0.027			41273	42273	45273	46273	
0.033			41333	42333	45333	46333	
0.039			41393	42393	45393	46393	
0.047			41473	42473	45473	46473	
0.056			41563	42563	45563	46563	
0.068			41683	42683	45683	46683	
0.082	5.0 x 14.0 x 10.5	0.4	41823	42823	45823	46823	
0.1			41104	42104	45104	46104	
0.12	5.5 x 15.0 x 10.5	0.6	41124	42124	45124	46124	
0.15	5.5 x 15.5 x 10.5	0.7	41154	42154	45154	46154	

## SPECIFIC REFERENCE DATA FOR THE 250V DC CAPACITORS

Description	Value		
	at 1kHz	at 10kHz	at 100kHz
Tangent of loss angle (unit : $10^{-4}$ ) $C \leq 0.1 \mu F$	$\leq 75$	$\leq 130$	$\leq 225$
$0.1 \mu F \square C \leq 0.47 \mu F$	$\leq 75$	$\leq 130$	$\leq 300$
Rated voltage pulse slope $(dV/dt)_R$ at 250V (DC)	70 V/ $\mu s$		
R between leads at 100V, for $C \leq 0.33 \mu F$	$\square 30\ 000 M\Omega$		
R between interconnected leads and casing; 100V ; 1min	$\square 30\ 000 M\Omega$		
Withstanding voltage DC (cut off current 10mA) ; rise time 100 V/s	400V ; 1min		

# Metallized Polyester film capacitors

PCMT 366

 $V_{Rdc} = 400\text{ V}$  $V_{Rac} = 220\text{ V}$ 

loose in box

Cap ( $\mu\text{F}$ )	$b_{\text{max}} \times h_{\text{max}} \times l_{\text{max}}$ (mm)	mas s (g)	CATALOGUE NUMBER PCMT 366 .....			
			loose in box			
			It = 17 $\pm$ 4 mm		It = 4 +1/-0.5 mm	
		C-tol. $\pm 10\%$	C-tol. $\pm 5\%$	C-tol. $\pm 10\%$	C-tol. $\pm 5\%$	
Pitch = 7.62 $\pm$ 0.3 mm			dt = 0.5 mm ( + 0.05 / - 0.05 )			
0.010	4.0 x 13.0 x 10.0	0.4	51103	52103	55103	56103
0.012			51123	52123	55123	56123
0.015			51153	52153	55153	56153
0.018	4.0 x 15.0 x 10.0	0.4	51183	52183	55183	56183
0.022	4.5 x 15.5 x 10.0	0.4	51223	52223	55223	56223
0.027	5.0 x 16.0 x 10.0	0.4	51273	52273	55273	56273
0.033	5.5 x 16.5 x 10.0	0.4	51333	52333	55333	56333
0.039	6.0 x 16.5 x 10.0	0.4	51393	52393	55393	56393
0.047	6.5 x 17.0 x 10.0	0.4	51473	52473	55473	56473
0.056	6.5 x 17.0 x 10.0	0.4	51563	52563	55563	56563

## SPECIFIC REFERENCE DATA FOR THE 400V DC CAPACITORS

Description	Value		
	at 1kHz	at 10kHz	at 100kHz
Tangent of loss angle (unit : $10^{-4}$ ) $C \leq 0.1\mu\text{F}$	$\leq 75$	$\leq 130$	$\leq 225$
Rated voltage pulse slope(dV/dt) <sub>R</sub> at 400V (DC)	110 V/ $\mu\text{s}$		
R between leads at 100V, for $C \leq 0.33\mu\text{F}$	$\square 30\ 000\ \text{M}\Omega$		
R between interconnected leads and casing;100V ; 1min	$\square 30\ 000\ \text{M}\Omega$		
Withstanding voltage DC ( cut off current 10mA ) ;rise time 100 V/s	640V ; 1min		

# Metallized Polyester film capacitors

PCMT 366

 $V_{Rdc} = 630 V$  $V_{Rac} = 250 V \sim$ 

loose in box

Cap ( $\mu F$ )	$b_{max} \times h_{max} \times l_{max}$ (mm)	mas s (g)	CATALOGUE NUMBER			
			PCMT 366 .....			
			loose in box			
			lt = 17 $\pm$ 4 mm		lt = 4 +1/-0.5 mm	
			C-tol. $\pm 10\%$	C-tol. $\pm 5\%$	C-tol. $\pm 10\%$	C-tol. $\pm 5\%$
Pitch = 7.62 $\pm$ 0.3 mm      dt = 0.5 mm ( + 0.05 / - 0.05 )						
0.010	5.0 x 14.5 x 10.0	0.4	61103	62103	65103	66103
0.012	5.5 x 15.0 x 10.0	0.4	61123	62123	65123	66123
0.015	6.0 x 15.5 x 10.0	0.5	61153	62153	65153	66153

## SPECIFIC REFERENCE DATA FOR THE 630V DC CAPACITORS

Description	Value		
	at 1kHz	at 10kHz	at 100kHz
Tangent of loss angle (unit : $10^{-4}$ ) $C \leq 0.1 \mu F$	$\leq 75$	$\leq 130$	$\leq 225$
Rated voltage pulse slope $(dV/dt)_R$ at 630V (DC)	110 V/ $\mu s$		
R between leads at 100V, for $C \leq 0.33 \mu F$	$\square 30\ 000\ M\Omega$		
R between interconnected leads and casing; 100V ; 1min	$\square 30\ 000\ M\Omega$		
Withstanding voltage DC ( cut off current 10mA ) ; rise time 100 V/s	1008V ; 1min		

# Metallized Polyester film capacitors

PCMT 367

 $V_{Rdc} = 63 V$  $V_{Rac} = 40 V$ 

loose in box

Cap ( $\mu F$ )	$b_{max} \times h_{max} \times l_{max}$ (mm)	mass (g)	CATALOGUE NUMBER			
			PCMT 367 .....			
			loose in box			
			It = 22 $\pm$ 4 mm		It = 4 +1/-0.5 mm	
		C-tol. $\pm 10\%$	C-tol. $\pm 5\%$	C-tol. $\pm 10\%$	C-tol. $\pm 5\%$	
Pitch = 5.08 $\pm$ 0.3 mm			dt = 0.5 mm ( + 0.05 / - 0.05 )			
0.047	3.5 x 7.5 x 7.5	0.3	71473	72473	75473	76473
0.056			71563	72563	75563	76563
0.068			71683	72683	75683	76683
0.082			71823	72823	75823	76823
0.1			71104	72104	75104	76104
0.12			71124	72124	75124	76124
0.15	4.0 x 8.0 x 7.5	0.3	71154	72154	75154	76154
0.18	4.5 x 8.5 x 7.5	0.3	71184	72184	75184	76184
0.22			71224	72224	75224	76224
0.27	5.0 x 9.0 x 7.5	0.3	71274	72274	75274	76274
0.33	5.5 x 9.5 x 7.5	0.3	71334	72334	75334	76334
0.39	5.5 x 10.5 x 7.5	0.3	71394	72394	75394	76394
0.47	6.0 x 11.5 x 7.5	0.4	71474	72474	75474	76474
0.56	5.5 x 10.0 x 7.5	0.4	71564	72564	75564	76564
0.68	5.5 x 10.5 x 7.5	0.4	71684	72684	75684	76684
0.82	6.0 x 11.0 x 7.5	0.5	71824	72824	75824	76824
1.0	6.5 x 11.5 x 7.5	0.5	71105	72105	75105	76105

## SPECIFIC REFERENCE DATA FOR THE 63V DC CAPACITORS

Description	Value		
	at 1kHz	at 10kHz	at 100kHz
Tangent of loss angle (unit : $10^{-4}$ )			
$C \leq 0.1 \mu F$	$\leq 75$	$\leq 130$	$\leq 225$
$0.1 \mu F \square C \leq 0.47 \mu F$	$\leq 75$	$\leq 130$	$\leq 300$
$0.47 \mu F \square C \leq 1.0 \mu F$	$\leq 75$	$\leq 130$	-
Rated voltage pulse slope $(dV/dt)_R$ at 63V (DC)	110 V/ $\mu s$		
R between leads at 10V , for $C \leq 0.33 \mu F$	$\square 15\ 000\ M\Omega$		
RC between leads at 10V, for $C \square 0.33 \mu F$	$\boxplus 5\ 000\ s$		
R between interconnected leads and casing; 100V ; 1min	$\square 30\ 000\ M\Omega$		
Withstanding voltage DC (cut off current 10mA) ; rise time 100 V/s	100V ; 1min		

**Metallized Polyester  
film capacitors**

PCMT 367

 $V_{Rdc} = 100 V$  $V_{Rac} = 63 V$ 

loose in box

Cap ( $\mu F$ )	$b_{max} \times h_{max} \times l_{max}$ (mm)	mass (g)	CATALOGUE NUMBER PCMT 367 .....					
			loose in box					
			It = 22 $\pm$ 4 mm		It = 4 +1/-0.5 mm			
			C-tol. $\pm 10\%$	C-tol. $\pm 5\%$	C-tol. $\pm 10\%$	C-tol. $\pm 5\%$		
Pitch = 5.08 $\pm$ 0.3 mm      dt = 0.5 mm ( + 0.05 / - 0.05 )								
0.01	3.5 x 7.5 x 7.5	0.3	81103	82103	85103	86103		
0.012			81123	82123	85123	86123		
0.015			81153	82153	85153	86153		
0.018			81183	82183	85183	86183		
0.022			81223	82223	85223	86223		
0.027			81273	82273	85273	86273		
0.033			81333	82333	85333	86333		
0.039			81393	82393	85393	86393		
0.047			81473	82473	85473	86473		
0.056			81563	82563	85563	86563		
0.068			81683	82683	85683	86683		
0.082			4.0 x 8.0 x 7.5	0.3	81823	82823	85823	86823
0.1					81104	82104	85104	86104

**SPECIFIC REFERENCE DATA FOR THE 100V DC CAPACITORS**

Description	Value		
	at 1kHz	at 10kHz	at 100kHz
Tangent of loss angle (unit : $10^{-4}$ ) $C \leq 0.1 \mu F$	$\leq 75$	$\leq 130$	$\leq 225$
$0.1 \mu F \square C \leq 0.27 \mu F$	$\leq 75$	$\leq 130$	$\leq 300$
Rated voltage pulse slope $(dV/dt)_R$ at 100V (DC)	110 V/ $\mu s$		
R between leads at 100V, for $C \leq 0.33 \mu F$	$\square 15\ 000\ M\Omega$		
R between interconnected leads and casing; 100V ; 1min	$\square 30\ 000\ M\Omega$		
Withstanding voltage DC (cut off current 10mA) ;rise time 100 V/s	160V ; 1min		

# Metallized Polyester film capacitors

PCMT 367

 $V_{Rdc} = 63 V$  $V_{Rac} = 40 V$ 

loose in box

Cap ( $\mu F$ )	$b_{max} \times h_{max} \times l_{max}$ (mm)	mass (g)	CATALOGUE NUMBER PCMT 367 .....			
			loose in box			
			It = 22 $\pm$ 4 mm		It = 4 +1/-0.5 mm	
			C-tol. $\pm 10\%$	C-tol. $\pm 5\%$	C-tol. $\pm 10\%$	C-tol. $\pm 5\%$
Pitch = 7.62 $\pm$ 0.3 mm			dt = 0.5 mm ( + 0.05 / - 0.05 )			
0.12	4.0 x 8.0 x 10.0	0.4	11124	12124	15124	16124
0.15			11154	12154	15154	16154
0.18			11184	12184	15184	16184
0.22			11224	12224	15224	16224
0.27	4.5 x 8.5 x 10.5	0.5	11274	12274	15274	16274
0.33	5.0 x 9.0 x 10.5	0.6	11334	12334	15334	16334
0.39			11394	12394	15394	16394
0.47	5.5 x 9.5 x 10.5	0.7	11474	12474	15474	16474
0.56	5.5 x 10.0 x 10.5	0.8	11564	12564	15564	16564
0.68			11684	12684	15684	16684
0.82			11824	12824	15824	16824
1.0			11105	12105	15105	16105

## SPECIFIC REFERENCE DATA FOR THE 63V DC CAPACITORS

Description	Value		
	at 1kHz	at 10kHz	at 100kHz
Tangent of loss angle (unit : $10^{-4}$ )			
$C \leq 0.1 \mu F$	$\leq 75$	$\leq 130$	$\leq 225$
$0.1 \mu F \square C \leq 0.47 \mu F$	$\leq 75$	$\leq 130$	$\leq 300$
$0.47 \mu F \square C \leq 1.0 \mu F$	$\leq 75$	$\leq 130$	-
Rated voltage pulse slope(dV/dt) <sub>R</sub> at 63V (DC)	18 V/ $\mu s$		
R between leads at 10V , for $C \leq 0.33 \mu F$	$\square 15\ 000\ M\Omega$		
RC between leads at 10V, for $C \square 0.33 \mu F$	$\boxplus 5\ 000\ s$		
R between interconnected leads and casing;100V ; 1min	$\square 30\ 000\ M\Omega$		
Withstanding voltage DC (cut off current 10mA) ;rise time 100 V/s	100V ; 1min		



**Metallized Polyester  
film capacitors**

PCMT 367

 $V_{Rdc} = 100 \text{ V}$  $V_{Rac} = 63 \text{ V}$ 

loose in box

Cap ( $\mu\text{F}$ )	$b_{\text{max}} \times h_{\text{max}} \times l_{\text{max}}$ (mm)	mass (g)	CATALOGUE NUMBER PCMT 367 .....			
			loose in box			
			lt = 22 $\pm$ 4 mm		lt = 4 +1/ - 0.5 mm	
			C-tol. $\pm 10\%$	C-tol. $\pm 5\%$	C-tol. $\pm 10\%$	C-tol. $\pm 5\%$
Pitch = 7.62 $\pm$ 0.3 mm      dt = 0.5 mm (+ 0.05 / - 0.05)						
0.039	4.0 x 8.0 x 10.0	0.4	21393	22393	25393	26393
0.047			21473	22473	25473	26473
0.056			21563	22563	25563	26563
0.068			21683	22683	25683	26683
0.082			21823	22823	25823	26823
0.10	4.0 x 8.5 x 10.0	0.4	21104	22104	25104	26104
0.12	4.5 x 9.0 x 10.5	0.5	21124	22124	25124	26124
0.15	5.0 x 9.5 x 10.5	0.5	21154	22154	25154	26154
0.18			21184	22184	25184	26184
0.22	5.5 x 10.0 x 10.5	0.7	21224	22224	25224	26224
0.27	6.0 x 10.5 x 10.5	0.7	21274	22274	25274	26274
0.33			21334	22334	25334	26334
0.39			21394	22394	25394	26394
0.47			21474	22474	25474	26474

**SPECIFIC REFERENCE DATA FOR THE 100V DC CAPACITORS**

Description	Value		
	at 1kHz	at 10kHz	at 100kHz
Tangent of loss angle (unit : $10^{-4}$ ) $C \leq 0.1 \mu\text{F}$	$\leq 75$	$\leq 130$	$\leq 225$
$0.1 \mu\text{F} \square C \leq 0.47 \mu\text{F}$	$\leq 75$	$\leq 130$	$\leq 300$
Rated voltage pulse slope $(dV/dt)_R$ at 100V (DC)	36 V/ $\mu\text{s}$		
R between leads at 100V, for $C \leq 0.33 \mu\text{F}$	$\square 15\,000 \text{ M}\Omega$		
RC between leads at 100V, for $C \square 0.33 \mu\text{F}$	$\boxtimes 5\,000 \text{ s}$		
R between interconnected leads and casing; 100V ; 1min	$\square 30\,000 \text{ M}\Omega$		
Withstanding voltage DC (cut off current 10mA) ; rise time 100 V/s	160V ; 1min		

# Metallized Polyester film capacitors

PCMT 367

 $V_{Rdc} = 250 V$  $V_{Rac} = 160 V$ 

loose in box

Cap ( $\mu F$ )	$b_{max} \times h_{max} \times l_{max}$ (mm)	mass (g)	CATALOGUE NUMBER PCMT 367.....			
			loose in box			
			It = 22 $\pm$ 4 mm		It = 4 +1/-0.5 mm	
			C-tol. $\pm 10\%$	C-tol. $\pm 5\%$	C-tol. $\pm 10\%$	C-tol. $\pm 5\%$
Pitch = 7.62 $\pm$ 0.3 mm			dt = 0.5 mm ( + 0.05 / - 0.05 )			
0.018	4.0 x 8.5 x 10.0	0.4	41183	42183	45183	46183
0.022			41223	42223	45223	46223
0.027			41273	42273	45273	46273
0.033			41333	42333	45333	46333
0.039			41393	42393	45393	46393
0.047			41473	42473	45473	46473
0.056			41563	42563	45563	46563
0.068			41683	42683	45683	46683
0.082			5.0 x 9.5 x 10.5	0.4	41823	42823
0.1	41104	42104			45104	46104
0.12	5.5 x 10.0 x 10.5	0.6	41124	42124	45124	46124
0.15	5.5 x 11.5 x 10.5	0.7	41154	42154	45154	46154

## SPECIFIC REFERENCE DATA FOR THE 250V DC CAPACITORS

Description	Value		
	at 1kHz	at 10kHz	at 100kHz
Tangent of loss angle (unit : $10^{-4}$ ) $C \leq 0.1 \mu F$	$\leq 75$	$\leq 130$	$\leq 225$
$0.1 \mu F$ □ $C \leq 0.47 \mu F$	$\leq 75$	$\leq 130$	$\leq 300$
Rated voltage pulse slope $(dV/dt)_R$ at 250V (DC)	70 V/ $\mu s$		
R between leads at 100V, for $C \leq 0.33 \mu F$	□ 30 000 M $\Omega$		
R between interconnected leads and casing; 100V ; 1min	□ 30 000 M $\Omega$		
Withstanding voltage DC (cut off current 10mA) ; rise time 100 V/s	400V ; 1min		

# Metallized Polyester film capacitors

PCMT 367

 $V_{Rdc} = 400 V$  $V_{Rac} = 220 V$ 

loose in box

Cap ( $\mu F$ )	$b_{max} \times h_{max} \times l_{max}$ (mm)	mass (g)	CATALOGUE NUMBER PCMT 367 ..... loose in box			
			It = 22 $\pm$ 4 mm		It = 4 +1/-0.5 mm	
			C-tol. $\pm 10\%$	C-tol. $\pm 5\%$	C-tol. $\pm 10\%$	C-tol. $\pm 5\%$
Pitch = 7.62 $\pm$ 0.3 mm      dt = 0.5 mm ( + 0.05 / - 0.05 )						
0.010	4.0 x 8.5 x 10.0	0.4	51103	52103	55103	56103
0.012			51123	52123	55123	56123
0.015			51153	52153	55153	56153
0.018	4.0 x 10.0 x 10.0	0.4	51183	52183	55183	56183
0.022	4.5 x 10.5 x 10.0	0.4	51223	52223	55223	56223
0.027	5.0 x 11.0 x 10.0	0.4	51273	52273	55273	56273
0.033	5.5 x 11.5 x 10.0	0.4	51333	52333	55333	56333
0.039	6.0 x 11.5 x 10.0	0.4	51393	52393	55393	56393
0.047	6.5 x 12.0 x 10.0	0.4	51473	52473	55473	56473
0.056	6.5 x 12.0 x 10.0	0.4	51563	52563	55563	56563

## SPECIFIC REFERENCE DATA FOR THE 400V DC CAPACITORS

Description	Value		
	at 1kHz	at 10kHz	at 100kHz
Tangent of loss angle (unit : $10^{-4}$ ) $C \leq 0.1 \mu F$	$\leq 75$	$\leq 130$	$\leq 225$
Rated voltage pulse slope(dV/dt) <sub>R</sub> at 400V (DC)	110 V/ $\mu s$		
R between leads at 100V, for $C \leq 0.33 \mu F$	$\square 30\ 000 M\Omega$		
R between interconnected leads and casing;100V ; 1min	$\square 30\ 000 M\Omega$		
Withstanding voltage DC ( cut off current 10mA) ;rise time 100 V/s	640V ; 1min		

# Metallized Polyester film capacitors

PCMT 367

 $V_{Rdc} = 630 V$  $V_{Rac} = 250 V$ 

loose in box

Cap ( $\mu F$ )	$b_{max} \times h_{max} \times l_{max}$ (mm)	mass (g)	CATALOGUE NUMBER			
			PCMT 367 .....			
			loose in box			
			It = 22 $\pm$ 4 mm		It = 4 +1/-0.5 mm	
		C-tol. $\pm 10\%$	C-tol. $\pm 5\%$	C-tol. $\pm 10\%$	C-tol. $\pm 5\%$	
Pitch = 7.62 $\pm$ 0.3 mm			dt = 0.5 mm ( + 0.05 / - 0.05 )			
0.010	5.0 x 9.5 x 10.0	0.4	61103	62103	65103	66103
0.012	5.5 x 10.0 x 10.0	0.4	61123	62123	65123	66123
0.015	6.0 x 10.5 x 10.0	0.5	61153	62153	65153	66153

## SPECIFIC REFERENCE DATA FOR THE 630V DC CAPACITORS

Description	Value		
	at 1kHz	at 10kHz	at 100kHz
Tangent of loss angle (unit : $10^{-4}$ ) $C \leq 0.1 \mu F$	$\leq 75$	$\leq 130$	$\leq 225$
Rated voltage pulse slope $(dV/dt)_R$ at 630V (DC)	110V/ $\mu s$		
R between leads at 100V, for $C \leq 0.33 \mu F$	$\square 30\ 000 M\Omega$		
R between interconnected leads and casing; 100V ; 1min	$\square 30\ 000 M\Omega$		
Withstanding voltage DC ( cut off current 10mA ) ; rise time 100 V/s	1008V ; 1min		

**MOUNTING**

**NORMAL USE**

The capacitors are designed for mounting on printed-circuit boards. The capacitors packed in bandoliers are designed for mounting on printed-circuit boards by means of automatic insertion machines. For detailed specifications refer to Chapter " PACKAGING "

**SPECIFIC METHOD OF MOUNTING TO WITHSTAND VIBRATION AND SHOCK**

In order to withstand vibration and shock tests, it must be ensured that the underside of the kinks are in good contact with the printed-circuit.

The capacitors shall be mechanically fixed by the leads

**STORAGE TEMPERATURE**

. Storage temperature :  $T_{stg} = - 25$  to  $+ 40^{\circ}\text{C}$  with RH maximum 80% without condensation.

**RATINGS AND CHARACTERISTICS**

specified all electrical values apply at an ambient temperature of  $23 \pm 1^{\circ}\text{C}$ , an atmospheric pressure of 86 to 106 kPa and a relative humidity of  $50 \pm 2\%$ .

For reference testing, a conditioning period shall be applied of  $96 \pm 4$  hours by heating the products in a circulating air oven at the rated temperature and a relative humidity not exceeding 20%.

**THE GRAPHS OF CHARACTERISTICS**

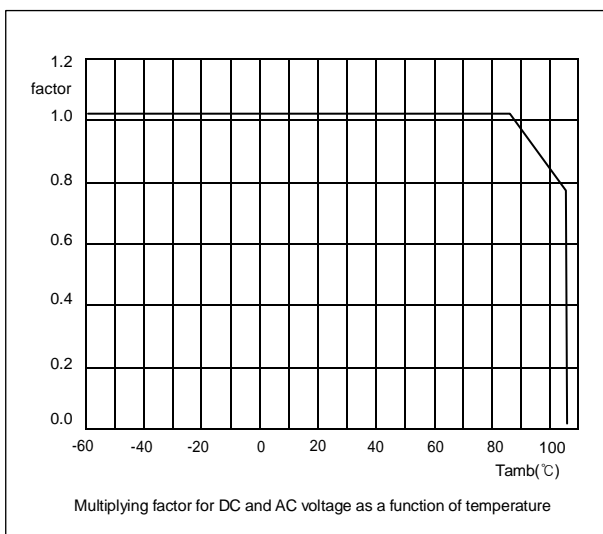
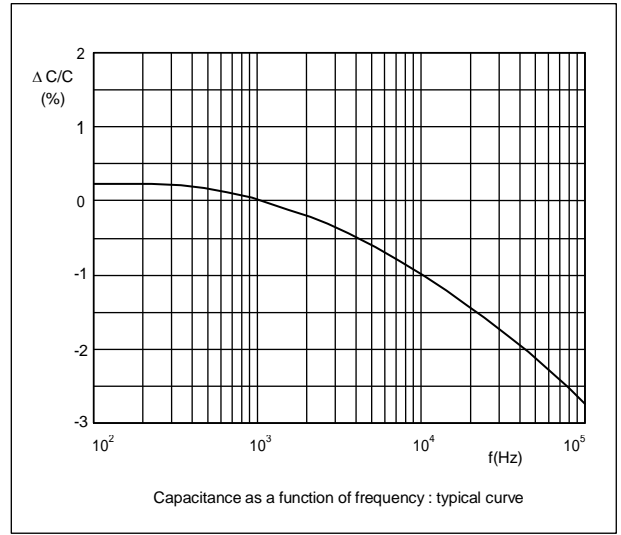
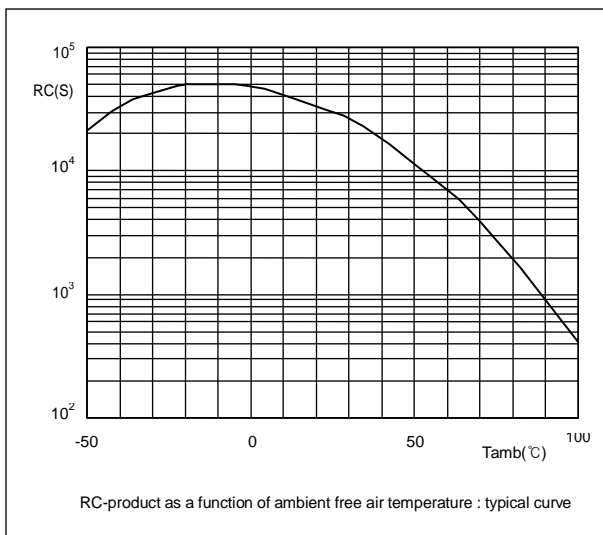
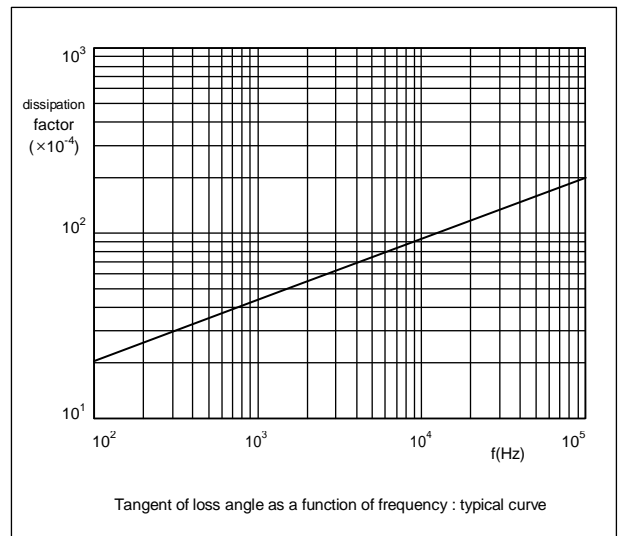
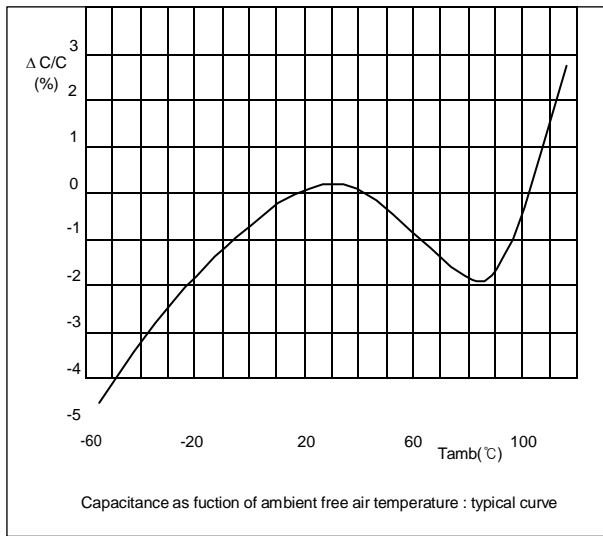

# Metallized Polyester film capacitors

# PCMT 365/366/367

## MAXIMUM RMS (63V, 100V, 250V) VOLTAGE (SENEWAVE) AS A FUNCTION OF FREQUENCY

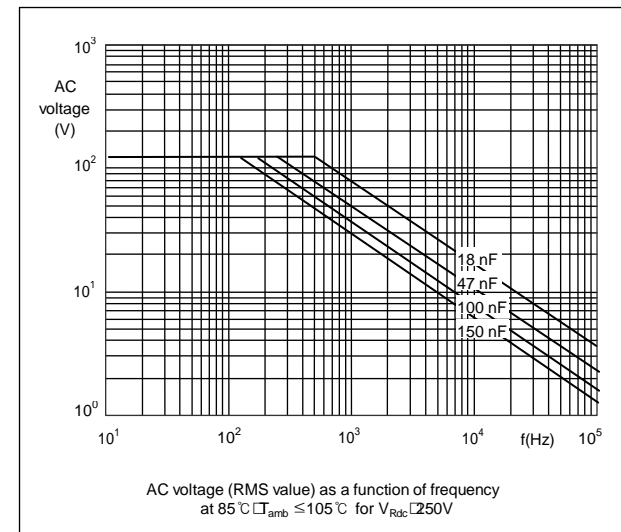
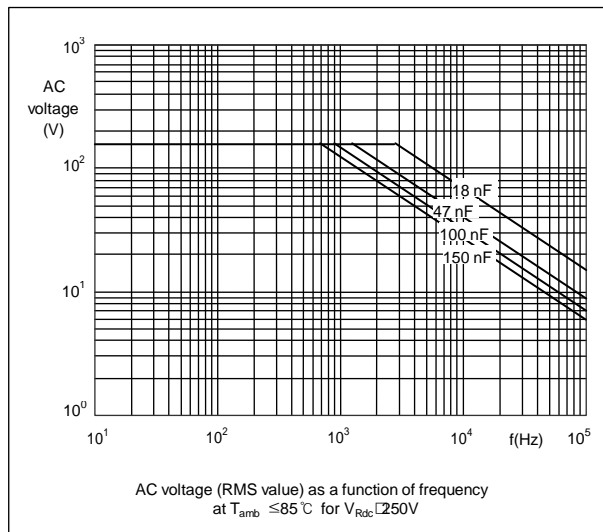
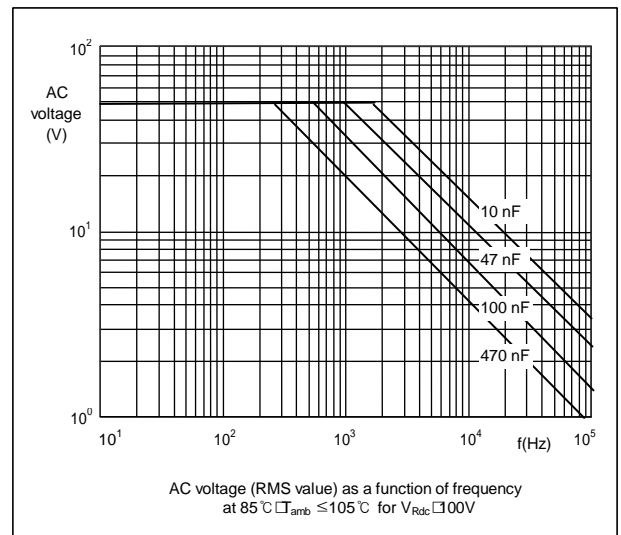
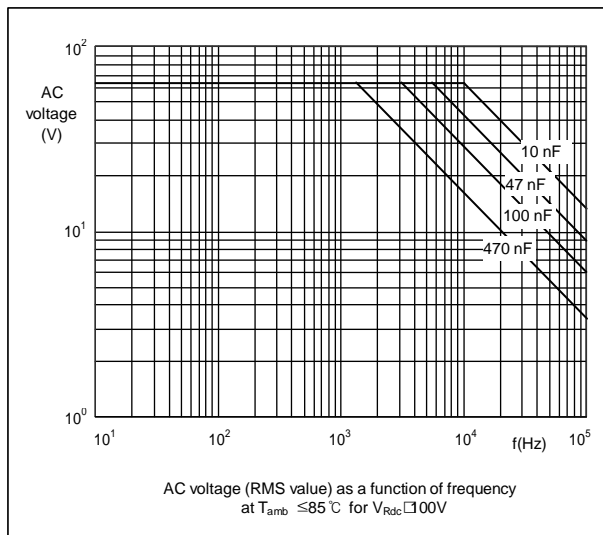
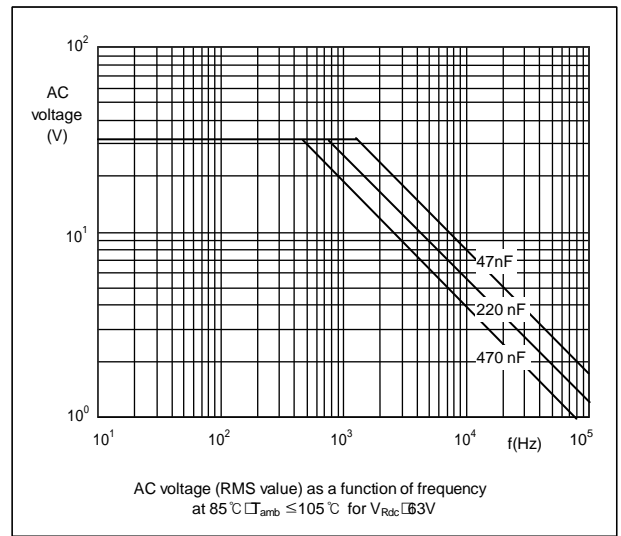
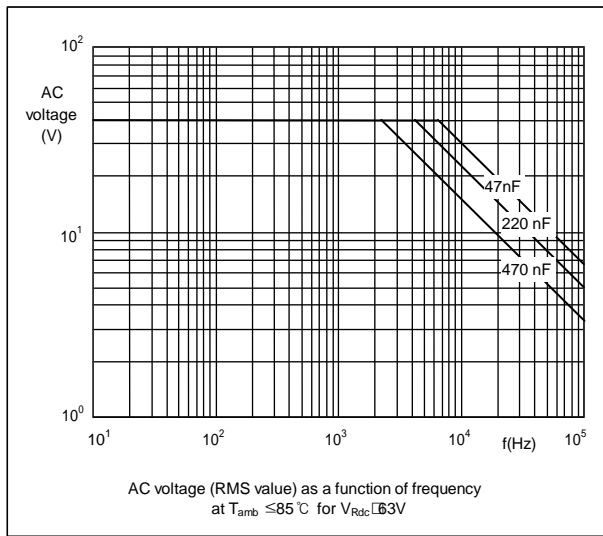

# Metallized Polyester film capacitors

# PCMT 365/366/367

## MAXIMUM RMS (400V, 630V) VOLTAGE (SINEWAVE) AS A FUNCTION OF FREQUENCY

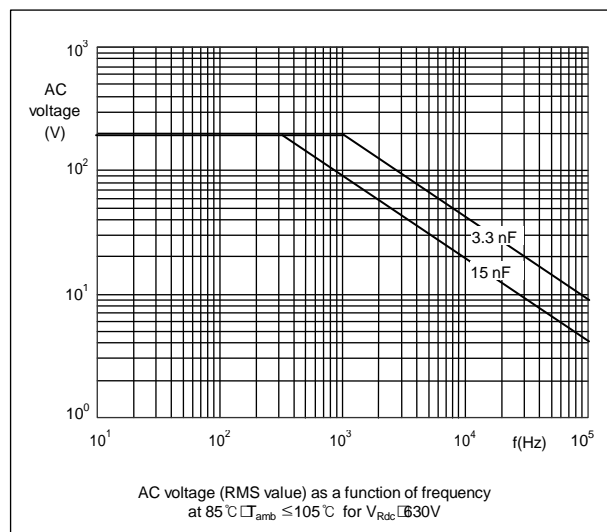
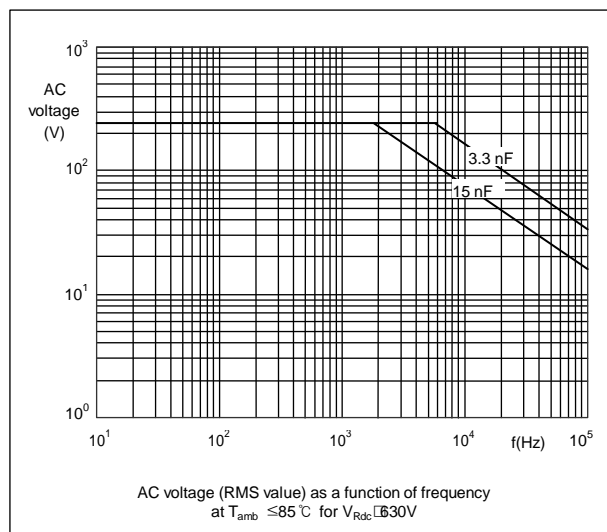
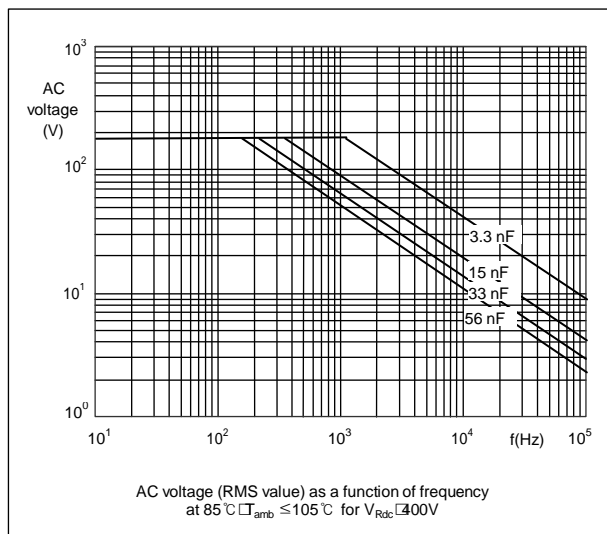
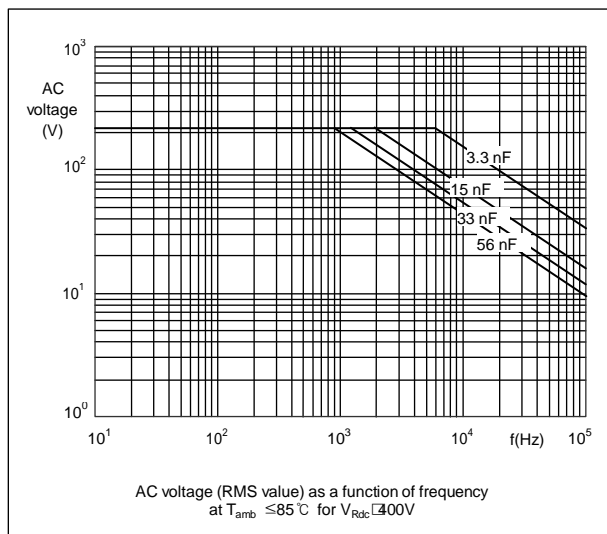



**APPLICATION NOTE AND LIMITING CONDITIONS**

To select this capacitor for a certain application, 6 conditions must be checked :

1. The peak voltage ( $V_p$ ) shall not be greater than the rated DC voltage.
2. The peak-to-peak voltage ( $V_{p-p}$ ) shall not be greater than  $2\sqrt{2}$  times the rated AC voltage to avoid the ionization inception level.
3. The peak current ( $I_p$ ) shall not exceed the maximum peak current, defined as maximum voltage pulse slope ( $dV/dt$ ) multiplied by the capacitance.

$$I_p \text{ max.} = C (dV/dt) \text{ max}$$

Or the voltage pulse slope shall not exceed the rated voltage pulse slope. If the pulse voltage is lower than the rated voltage, the values of the table may be multiplied by  $V_{Rdc}$  and divided by the applied voltage.

4. The dissipated power shall not be greater than the maximum permissible power dissipation stated above.
5. The free air ambient temperature for the capacitor is not exceeding the category temperature.
6. Since all metallized film capacitors have an intrinsically active flammability risk, it is recommended that these capacitors should only be used in circuits where the power can be limited to less than 5W to the capacitor, should a failure occur.

**PRODUCT MARKING****Capacitors with a body length  $\leq$  7.5 mm**

The capacitors are marked on the top or side in black ink with the following information :

- . Rated capacitance code in  $\text{pF}$  or  $\mu\text{F}$
- . Tolerance on rated capacitance : K =  $\pm 10\%$ , J =  $\pm 5\%$
- . Rated DC voltage

**Example of marking**

0.047 K. 63	or	0.047 K 63
----------------	----	---------------

**Capacitors with a body length of 10 mm or 10.5 mm**

The capacitors are marked on the top or side in black ink with the following information :

- . Rated capacitance code in  $\text{pF}$  or  $\mu\text{F}$
- . Tolerance on rated capacitance : K =  $\pm 10\%$ , J =  $\pm 5\%$
- . Rated DC voltage
- . Code for dielectric material

**Example of marking**

0.47 K 100 MKT.	or	0.47 K 100 MK
--------------------	----	------------------

