

DC Compact Fans – 280A Metal

280 x 280 x 80 mm

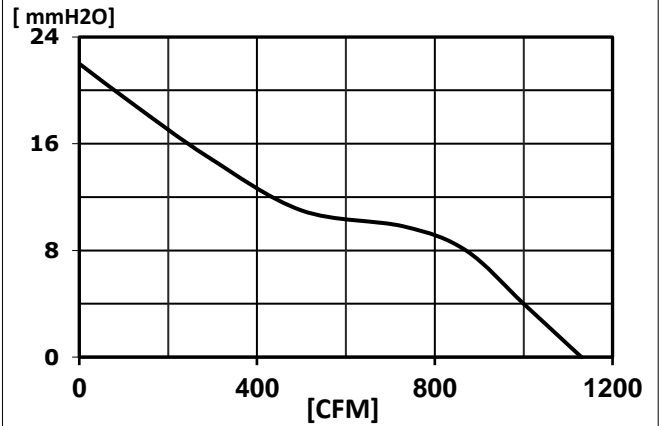

- Bearing System** : Ball
- Blade** : Sheet steel, Coated in black
- Motor** : DC Brushless motor
- Housing** : Aluminium Die casting
- Locked motor Protection** : Electronic Shut Down When locking Rotor and Automatically restart.
- IP Protection** : IP20

- Insulation Resistance** : $\geq 50M \Omega$ at 500V DC
- Dielectric Strength** : $\geq 0.5KV$ AC for 1 min.
- Insulation Class** : Class A
- Protection against** : Reverse connection
- Operating Temperature** : $-10^{\circ}C \sim +60^{\circ}C$
- Product Life** : 50,000 hours

Model	Voltage	Current	Speed	Watt	Air Flow	Static Pressure	Noise
	V AC	mA	RPM	W	CFM	mm H ₂ O	dBA
280A48HBDC-M	48	2460	2750	100	1130	22	69

Drawing:-

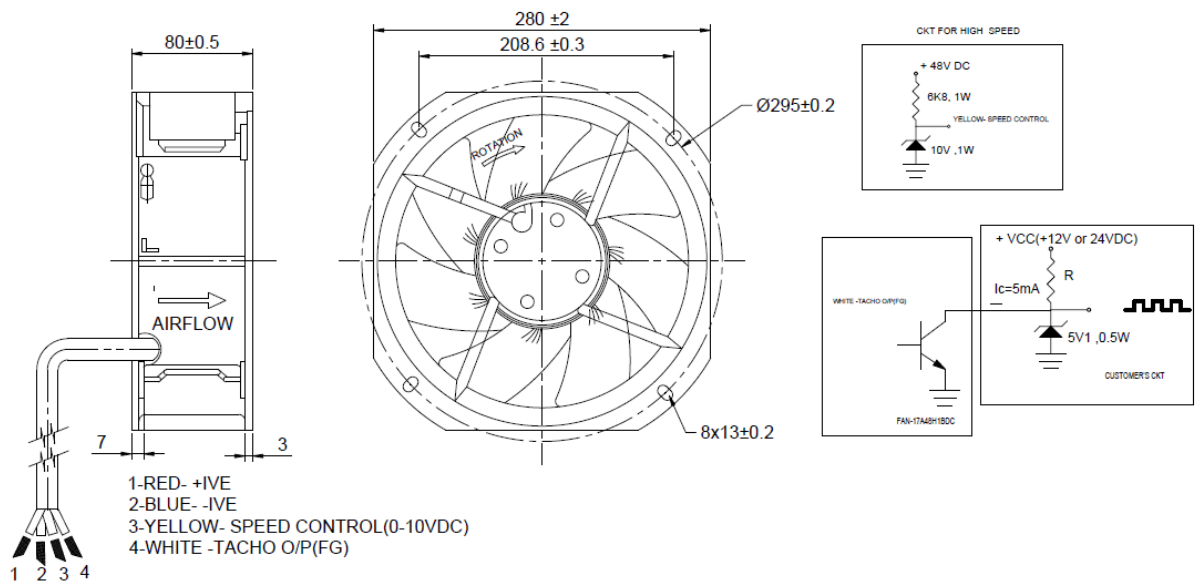

Note:-
As Part of a green initiative, Hicool is constantly working to reduce power consumption without altering fan motor Performance. Actual Current & Wattage readings Can be lower than mentioned in datasheet & fan name plate.