

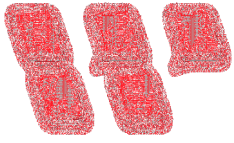

a2zelectronic.com

Sourcing Simplified





# Winstar Display Co., LTD

## 華凌光電股份有限公司



WEB: <http://www.winstar.com.tw>

E-mail: [winstar@winstar.com.tw](mailto:winstar@winstar.com.tw)

### SPECIFICATION

**CUSTOMER :** \_\_\_\_\_

**MODULE NO.:** WF35LTIACDNN0#

<p><b>APPROVED BY:</b> ( FOR CUSTOMER USE ONLY )</p>	<p><b>PCB VERSION:</b> _____ <b>DATA:</b> _____</p>
--	---

SALES BY	APPROVED BY	CHECKED BY	PREPARED BY
			葉虹蘭
<b>ISSUED DATE: 2014/05/09</b>			

TFT Display Inspection Specification: <http://www.winstar.com.tw/service.php>

**RECORDS OF REVISION**

**DOC. FIRST ISSUE**

VERSION	DATE	REVISED PAGE NO.	<b>SUMMARY</b>
0	2012/10/25		First issue
A	2013/10/31		Update Optical Characteristics
B	2014/05/09		Modify Package Specification.

# Contents

1.Module Classification Information

2.Summary

3.General Specification

4.Absolute Maximum Ratings

5.Electrical Characteristics

6.DC Characteristics

7.AC Characteristics

8.Optical Characteristics

9.Interface

10.Block Diagram

11.Reliability

12.Contour Drawing

13.Package Specification

14.Other

# 1. Module Classification Information

W	F	35	L	T	I	A	C	D	N	N	0	#
①	②	③	④	⑤	⑥	⑦	⑧	⑨	⑩	⑪	⑫	⑬

①	Brand : WINSTAR DISPLAY CORPORATION												
②	Display Type : F→TFT Type, J→Custom TFT												
③	Display Size : 3.5" TFT												
④	Model serials no.												
⑤	Backlight Type :	F→CCFL, White S→LED, High Light White						T→LED, White					
⑥	LCD Polarize Type/ Temperature range/ Gray Scale Inversion Direction	I→Transmissive, W. T, 6:00 L→Transmissive, W.T,12:00 Z→Transmissive, W.T, Wide Viewing Angle for O-FILM Y→Transmissive, W.T, Wide View											
⑦	A : TFT LCD B : TFT+FR+CONTROL BOARD C : TFT+FR+A/D BOARD D : TFT+FR+A/D BOARD+CONTROL BOARD E : TFT+FR+POWER BOARD F : TFT+CONTROL BOARD						G : TFT+FR H : TFT+D/V BOARD I : TFT+FR+D/V BOARD J : TFT+POWER BD						
⑧	Solution:												
	A: 128160	B:320234	C:320240	D:480234	E:480272	F: 640480	G: 800480						
	H:1024600	I:320480	J:240320	K:800600	L:240400	M :1024768	P :1280800						
⑨	D: Digital L : LVDS												
⑩	Interface : N : without control board A : 8Bit B : 16Bit												
⑪	TS : N : Without TS T : resistive touch panel C : capacitive touch panel												
⑫	Version												
⑬	Special Code	#:Fit in with ROHS directive regulations											

## **2.Summary**

This technical specification applies to 3.45' color TFT-LCD panel. The 3.45' color TFT-LCD panel is designed for camcorder, digital camera application and other electronic products which require high quality flat panel displays. This module follows RoHS.

### 3. General Specifications

Item	Dimension	Unit
Dot Matrix	320 x RGBx240(TFT)	dots
Module dimension	76.9(W) x 63.9(H) x 3.26(D)	mm
Active area	70.08 x 52.56	mm
Dot pitch	0.073 x 0.219	mm
LCD type	TFT, Normally White, Transmissive	
View Direction	12 o'clock	
Gray Scale Inversion Direction	6 o'clock	
Backlight Type	LED, Normally White	

\*Color tone slight changed by temperature and driving voltage.

# 4. Absolute Maximum Ratings

Item	Symbol	Min	Typ	Max	Unit
Operating Temperature	TOP	-20	—	+70	°C
Storage Temperature	TST	-30	—	+80	°C

Note: Device is subject to be damaged permanently if stresses beyond those absolute maximum ratings listed above

- Temp.  $\leq 60^{\circ}\text{C}$ , 90% RH MAX. Temp.  $> 60^{\circ}\text{C}$ , Absolute humidity shall be less than 90% RH at  $60^{\circ}\text{C}$

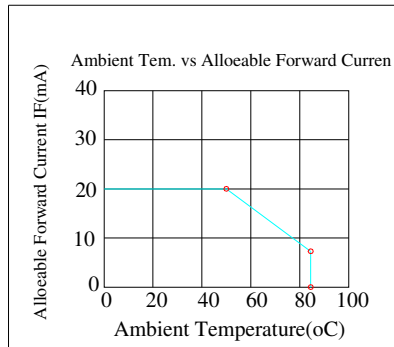



# 5. Electrical Characteristics

## 5.1. Operating conditions:

Item	Symbol	Condition	Min	Typ	Max	Unit	Remark
Supply Voltage For LCM	VCC	—	3.0	3.3	3.6	V	
Supply Current For LCM	ICC	—	—	8.6	15	mA	Note 1

Note 1 : This value is test for VDD=3.3V , Ta=25 °C only

## 5.2. LED driving conditions

Parameter	Symbol	Min.	Typ.	Max.	Unit	Remark
LED current		-	20	-	mA	
Power Consumption		348	384	408	mW	
LED voltage	LED+	17.4	19.2	20.4	V	Note 1
LED Life Time		-	50,000	-	Hr	Note 2,3,4

Note 1 : There are 1 Groups LED

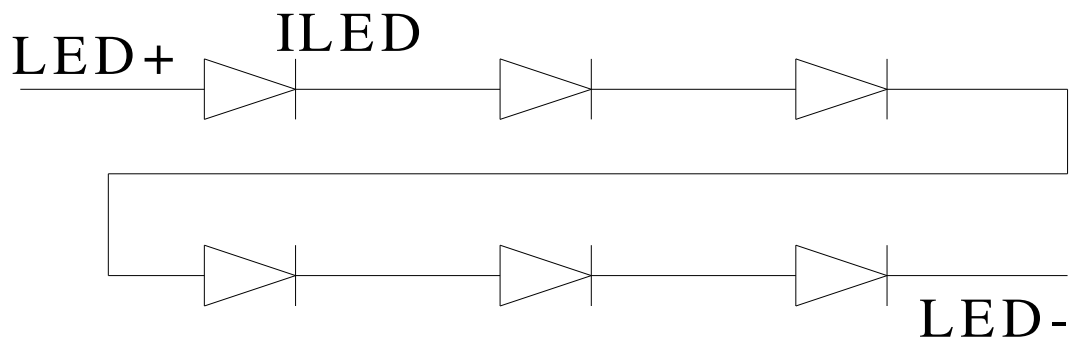

Note 2 : Ta = 25 °C

Note 3 : Brightness to be decreased to 50% of the initial value

Note 4 : The single LED lamp case

## 6.DC CHARATERISTICS

Parameter	Symbol	Rating			Unit	Condition
		Min	Typ	Max		
Low level input voltage	$V_{IL}$	0	-	0.3VCC	V	
High level input voltage	$V_{IH}$	0.7VCC	-	VCC	V	

# 7.AC Characteristics

## Digital Parallel RGB interface

Signal	Item	Symbol	Min	Typ	Max	Unit
Dclk	Frequency	Tosc	-	6.5	10	MHz
	High Time	Tch	-	77	-	ns
	Low Time	Tcl	-	77	-	ns
Data	Setup Time	Tsu	12	-	-	ns
	Hold Time	Thd	12	-	-	ns
Hsync	Period	TH	-	408	-	Tosc
	Pulse Width	THS	5	30	-	Tosc
	Back-Porch	Thb	-	38	-	Tosc
	Display Period	TEP	-	320	-	Tosc
	Hsync-den time	THE	36	68	88	-
	Front-Porch	Thf	-	20	-	Tosc
Vsync	Period	Tv	-	262	-	TH
	Pulse Width	Tvs	1	3	5	TH
	Back-Porch	Tvb	-	15	-	TH
	Display Period	Tvd	-	240	-	TH
	Front-Porch	Tvf	2	4	-	TH

Note:

1.  $T_h + T_{hb} = 68$ , the user is make up by yourself.
2.  $T_v = T_{vs} + T_{vb} + T_{vd} + T_{vf}$ , the user is make up by yourself.
3. When SYNC mode is used, 1st data start from 68th Dclk after Hsync falling

## CCIR601/656 Interface

Signal	Item	Symbol	Min	Typ	Max	Unit
Dclk	Frequency	Tosc	-	37	-	ns
	High Time	Tch	-	78	-	ns
	Low Time	Tcl	-	78	-	ns
Data	Setup Time	Tsu	12	-	-	ns
	Hold Time	Thd	12	-	-	ns

## 7.1. Waveform

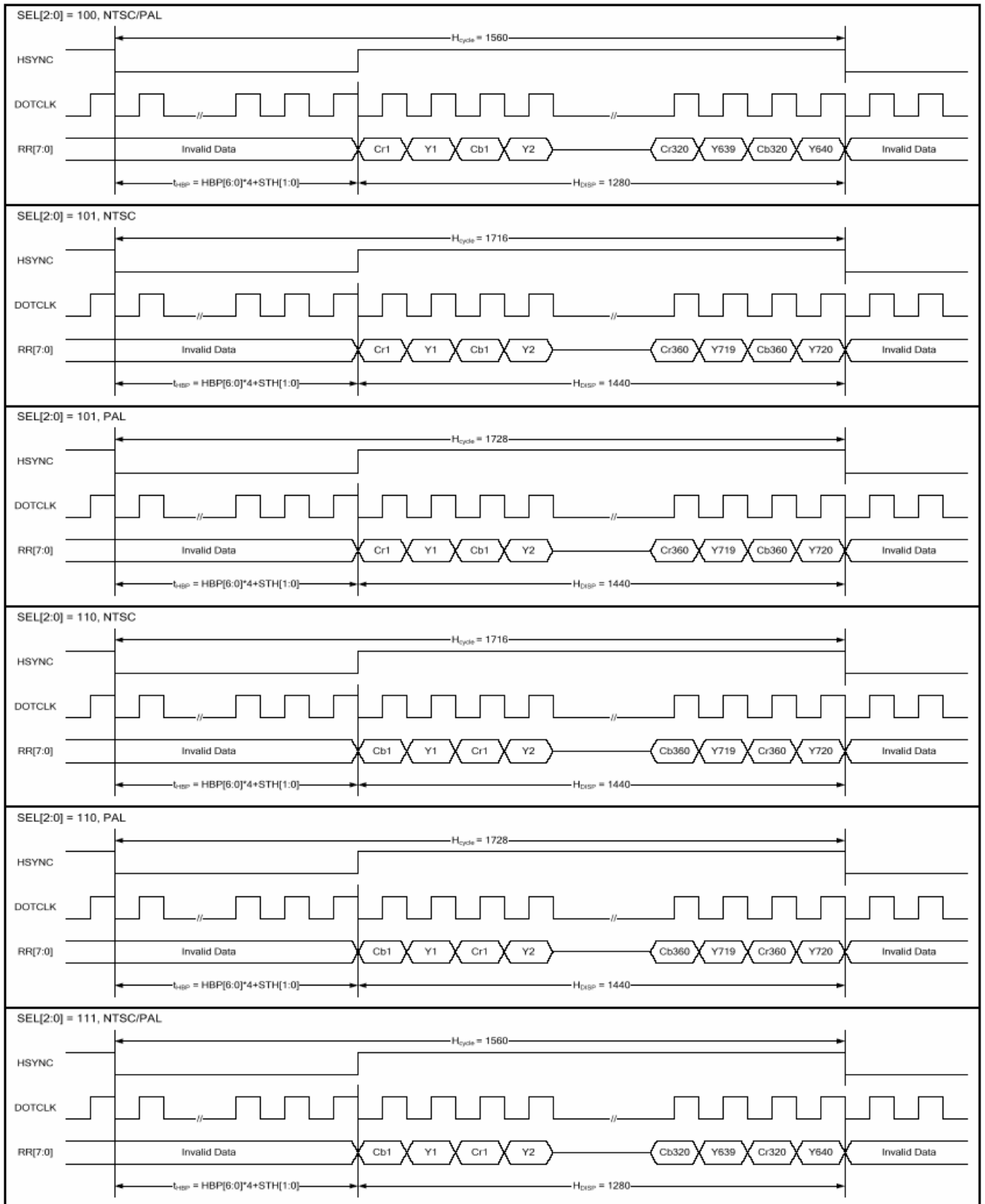

Figure 1 CCIR601 Horizontal Timing

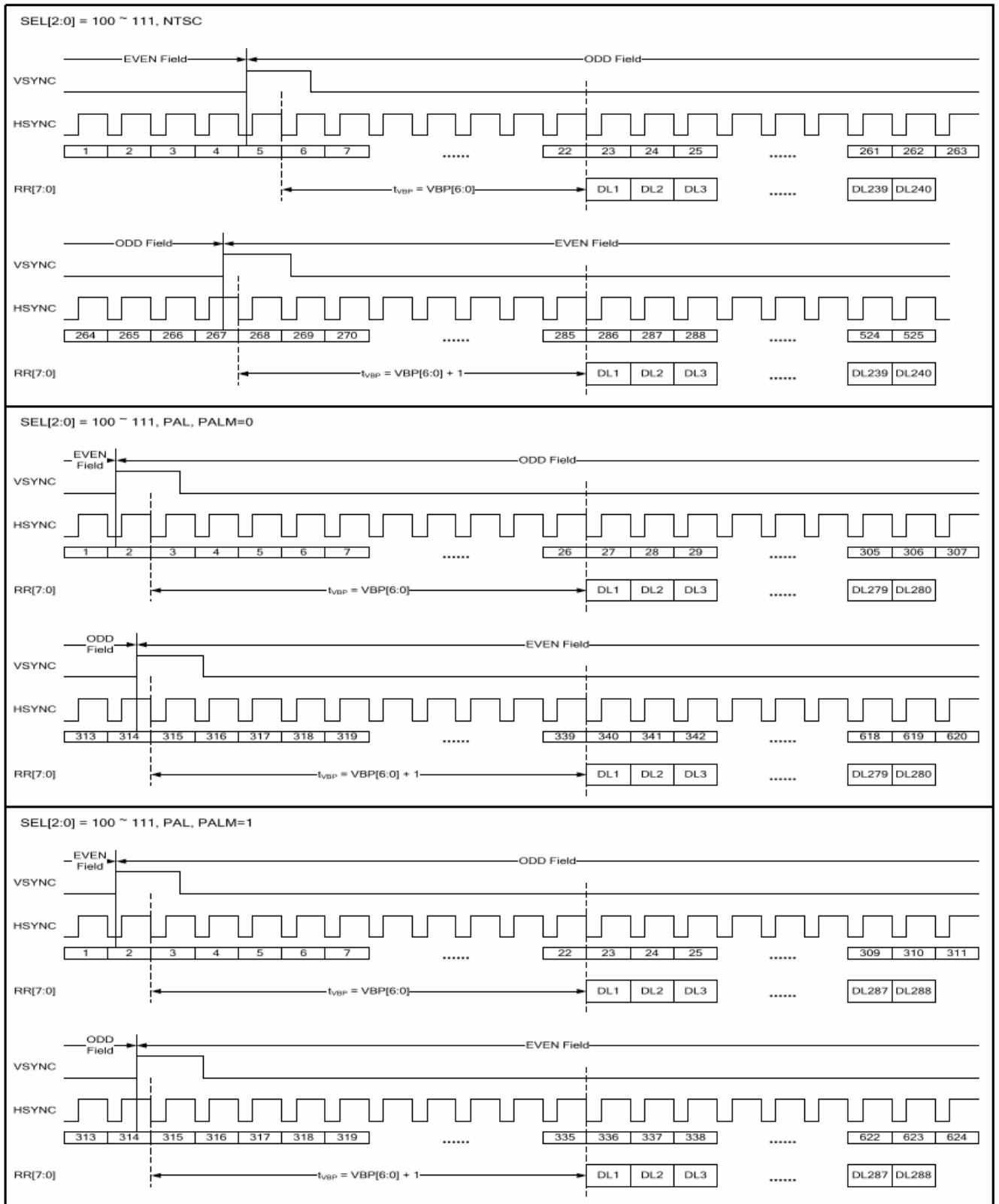

Figure 1 CCIR601 Vertical Timing

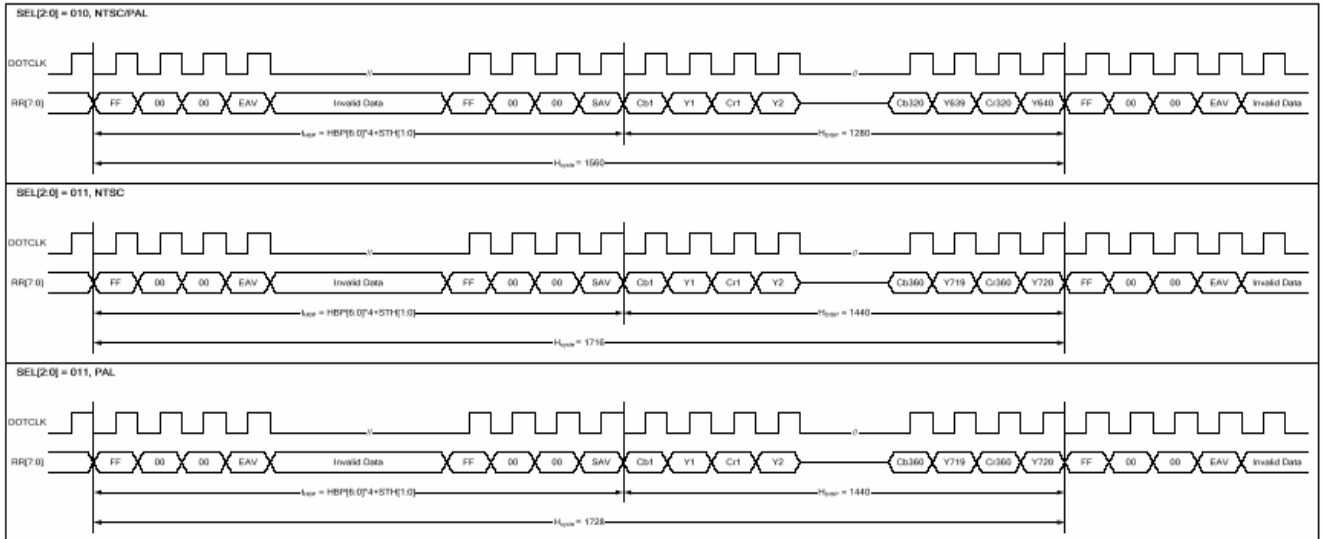

Figure 2 CCIR656 Horizontal Timing

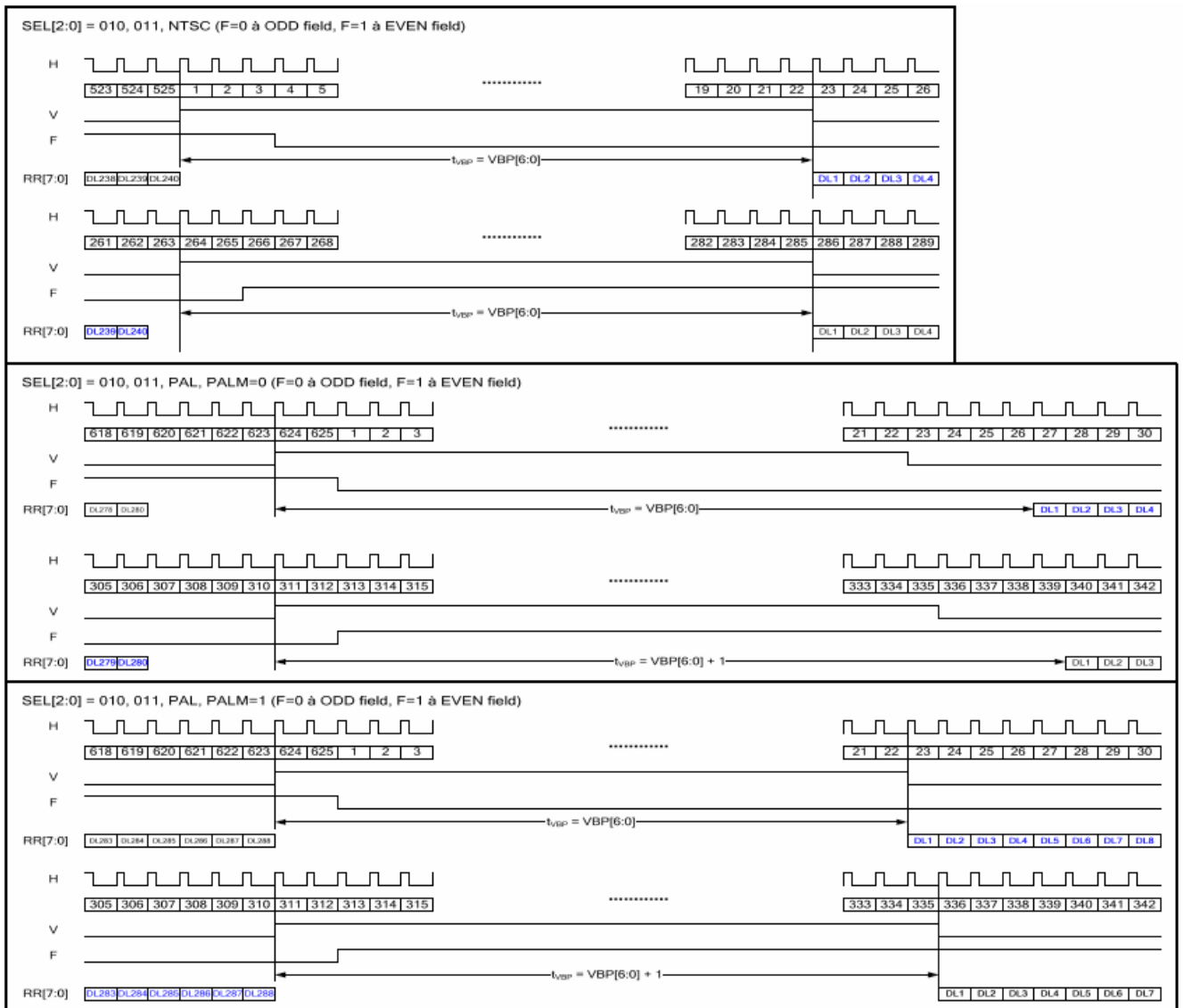

Figure 2 CCIR656 Vertical Timing

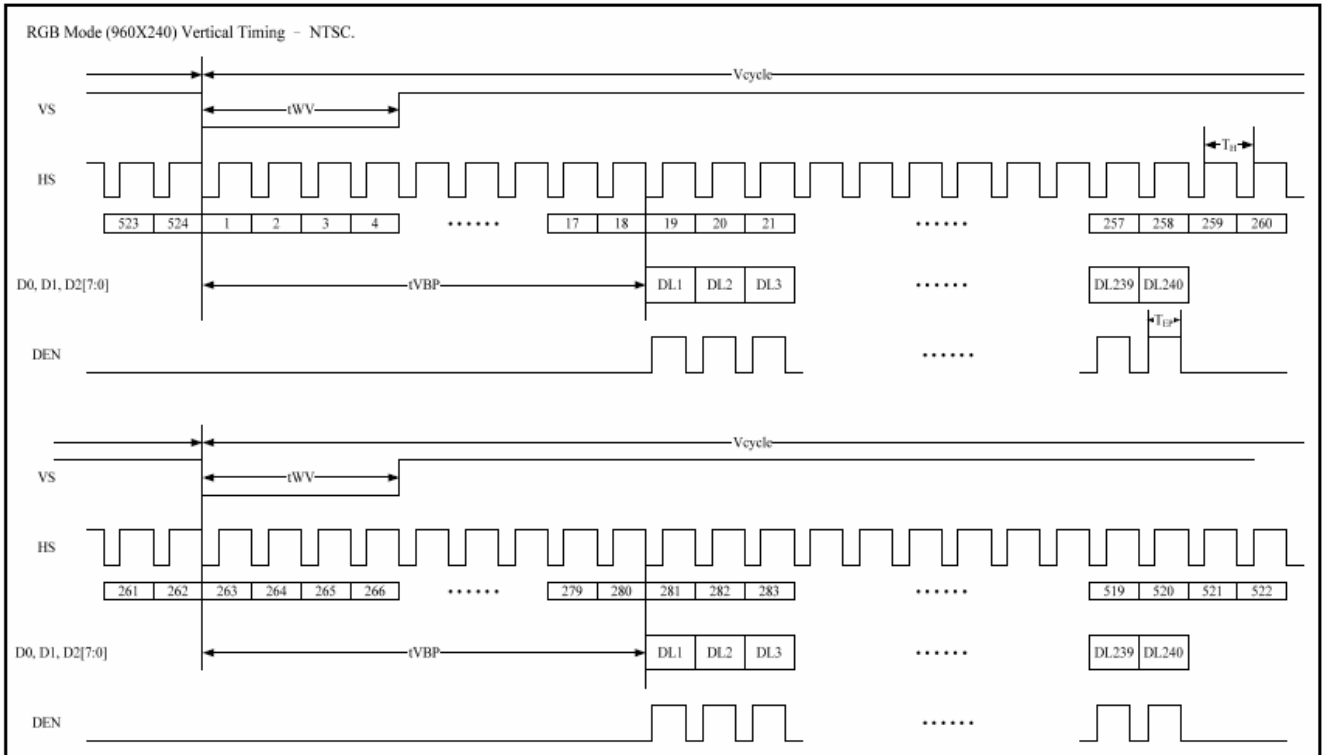
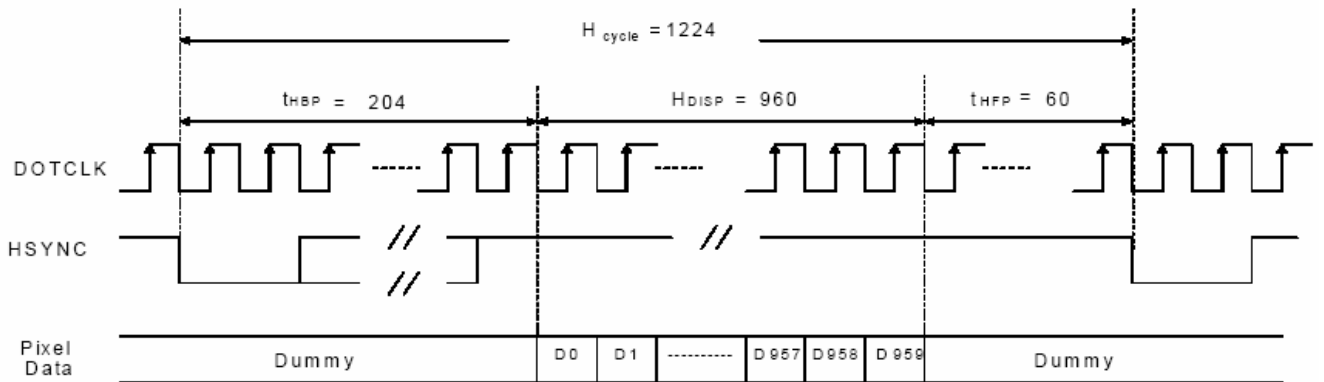
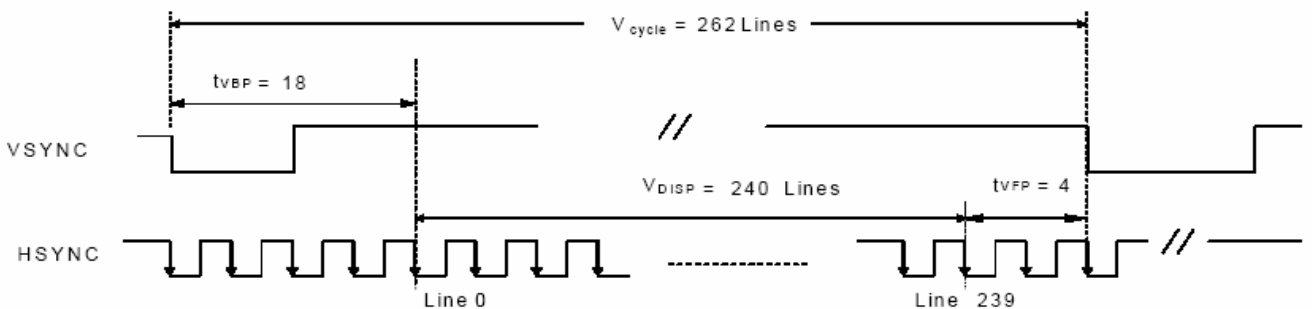

Figure 3 Digital RGB NTSC mode Vertical Data Format for 262T<sub>H</sub>



a) Horizontal Data Transaction Timing



Vertical Data Transaction Timing

Figure 3 Data Transaction Timing in Serial RGB (8 bit) Interface (SYNC Mode)

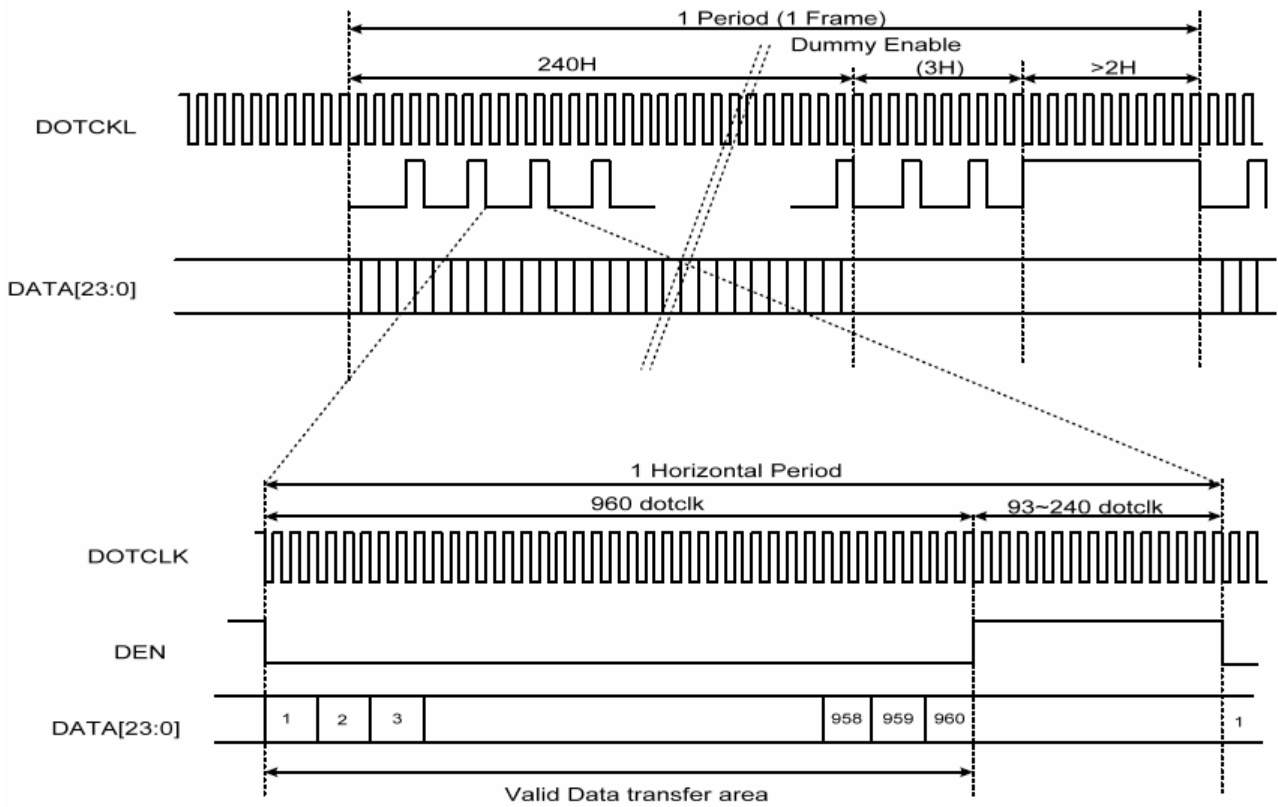
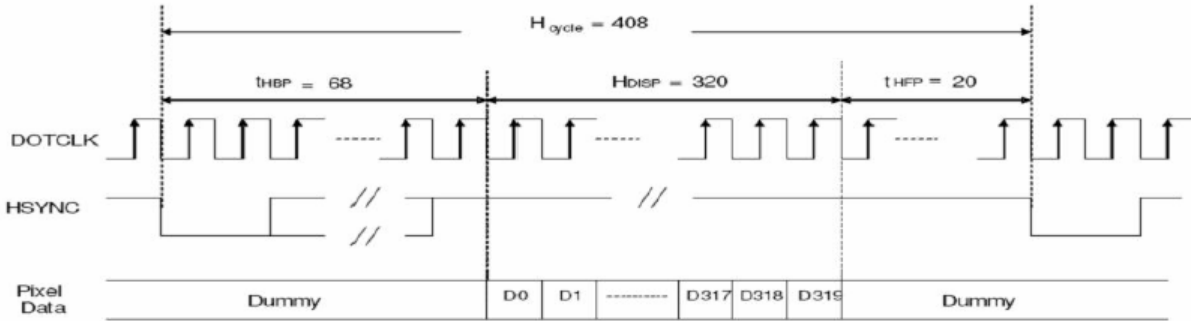
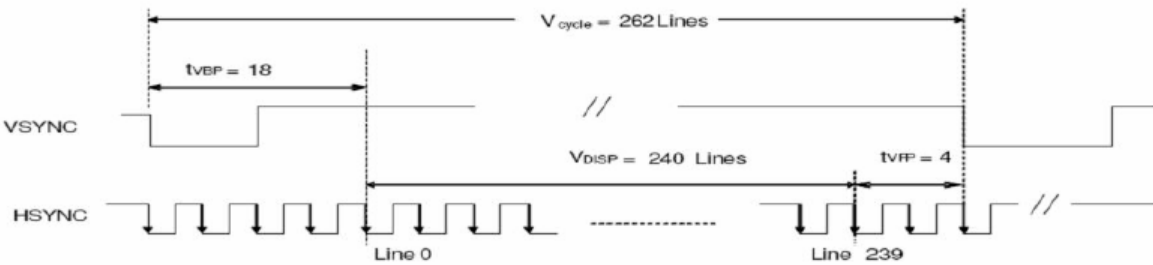

Figure 3 Data Transaction Timing in Serial RGB (8 bit) Interface (DE Mode)



a) Horizontal Data Transaction Timing



b) Vertical Data Transaction Timing

Figure 3 Data Transaction Timing in Parallel RGB (24 bit) Interface (SYNC Mode)



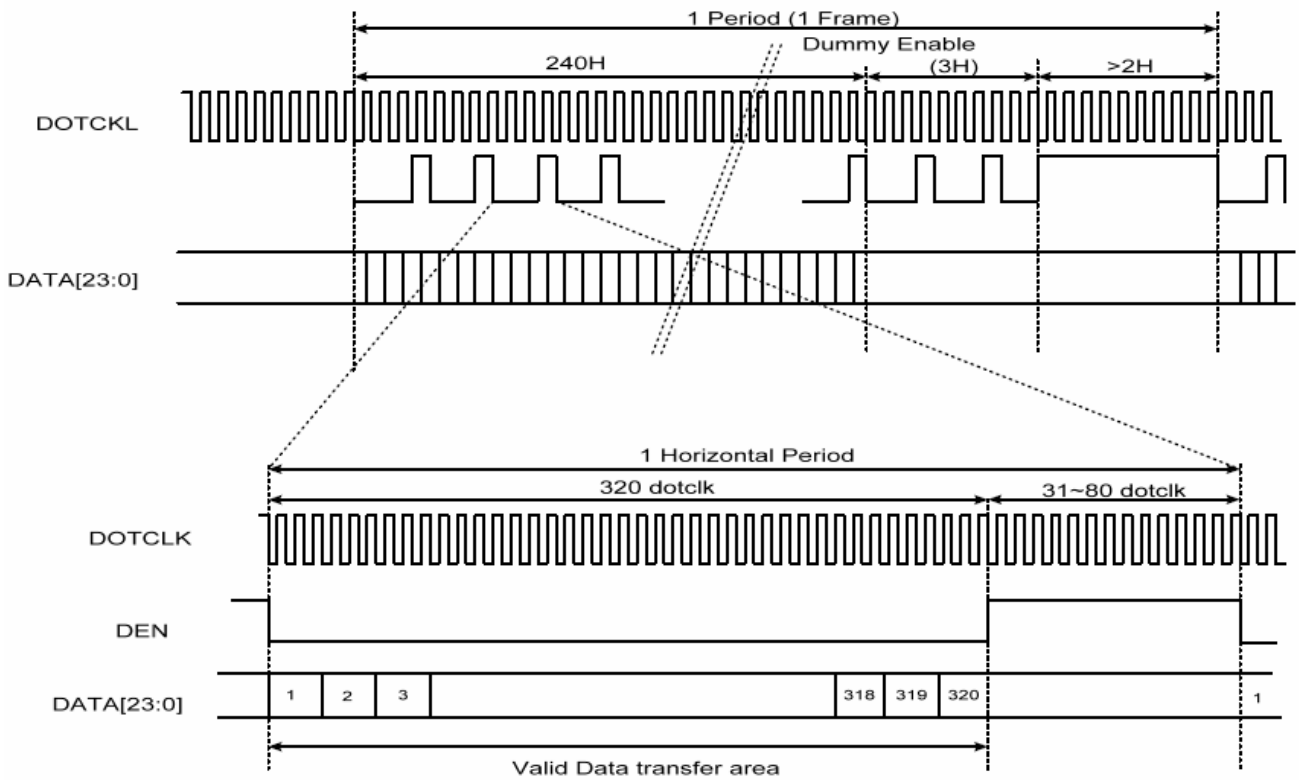

Figure 3 Data Transaction Timing in Parallel RGB (24 bit) Interface (DE Mode)

## 7.2. Clock and Sync waveforms

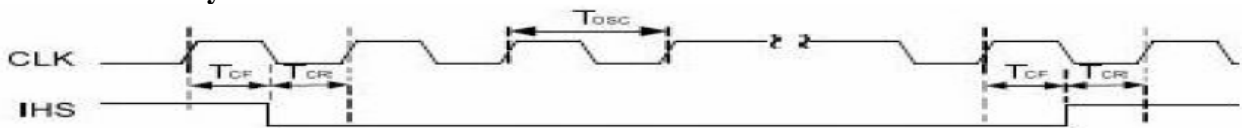

Figure 6 CLK and IHS timing waveform

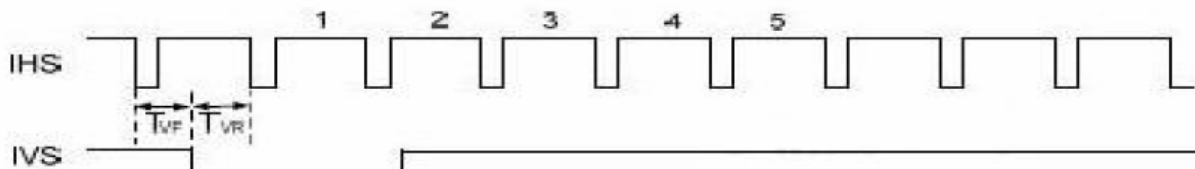
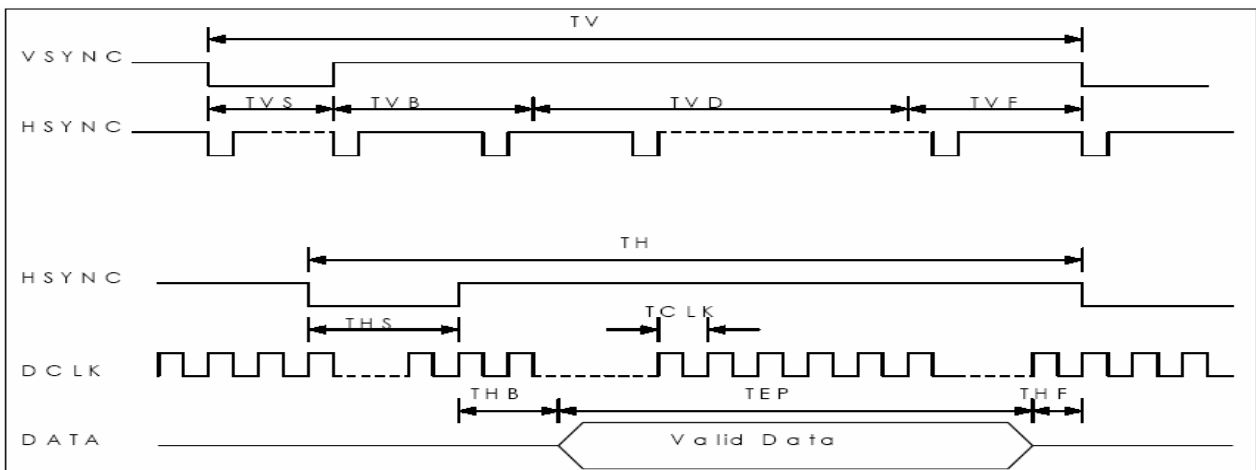
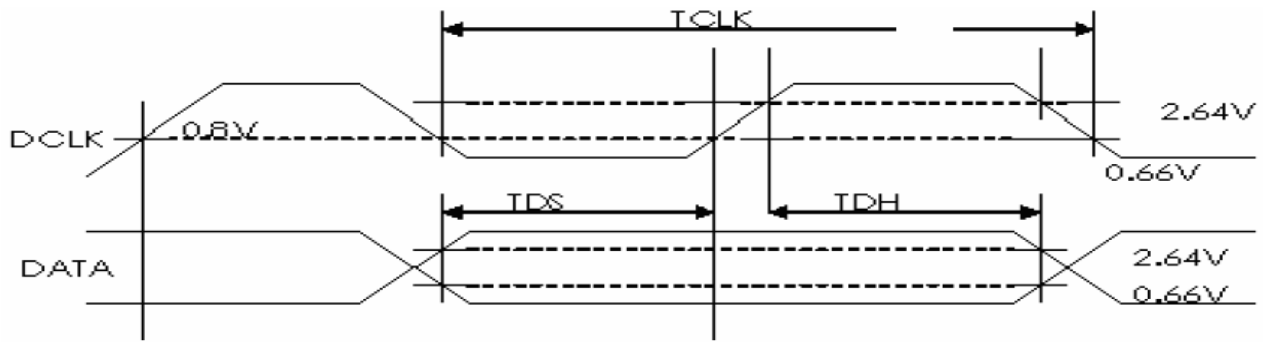

Figure 4 IHS and IVS timing waveforms





### 7.3. Reset Timing Chart

The RESET input must be held at least 1ms after power is stable

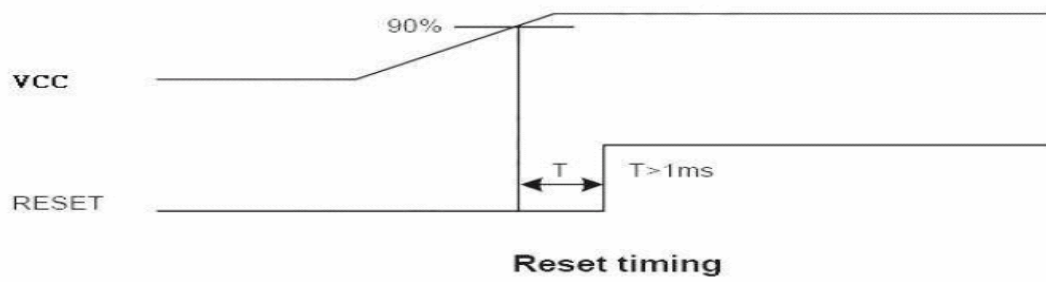

# 8. Optical Characteristics

Item	Symbol	Condition.	Min	Typ.	Max.	Unit	Remark	
Response time	$T_r$	$\theta = 0^\circ$ 、 $\Phi = 0^\circ$	-	10	-	ms	Note 3,5	
	$T_f$		-	15	-	ms		
Contrast ratio	CR	At optimized viewing angle	300	350	-	-	Note 4,5	
Color Chromaticity	White	$\theta = 0^\circ$ 、 $\Phi = 0^\circ$	$W_x$	0.26	0.31	0.36	-	Note 2,6,7
			$W_y$	0.28	0.33	0.38	-	-
Viewing angle	Hor.	$CR \geq 10$	$\Theta_R$	-	55	-	Deg.	Note 1
			$\Theta_L$	-	55	-		
	Ver.		$\Phi_T$	-	45	-		
			$\Phi_B$	-	50	-		
Brightness	-	-	350	420	-	cd/m <sup>2</sup>	Center of display	

Ta=25±2°C, IL=20mA

Note 1: Definition of viewing angle range

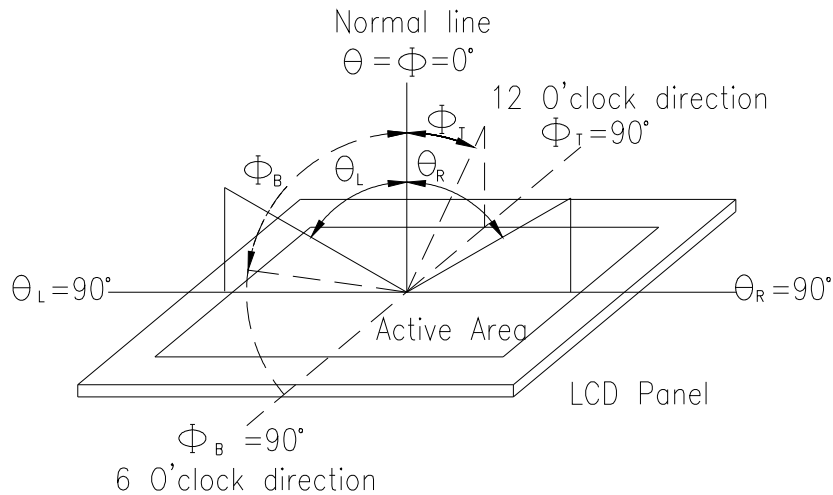

Fig. 8.1. Definition of viewing angle

Note 2: Test equipment setup:

After stabilizing and leaving the panel alone at a driven temperature for 10 minutes, the measurement should be executed. Measurement should be executed in a stable, windless, and dark room. Optical specifications are measured by Topcon BM-7 or BM-5 luminance meter 1.0° field of view at a distance of 50cm and normal direction.

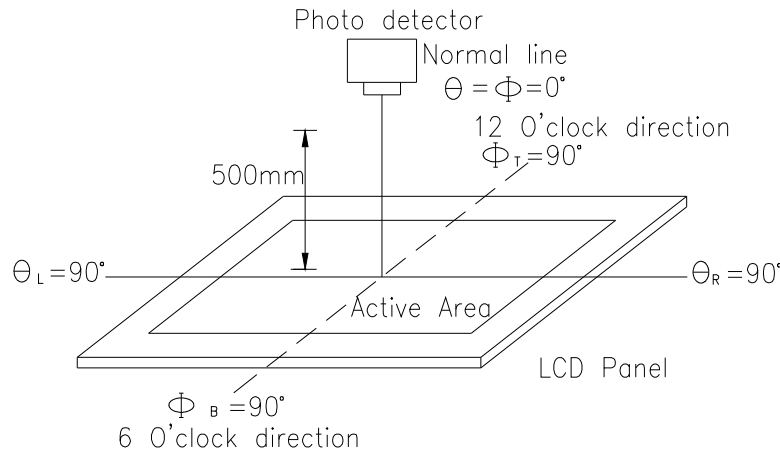
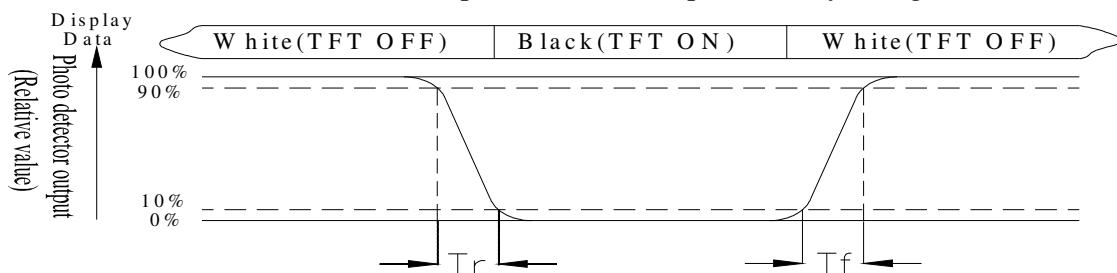

Fig. 8.2. Optical measurement system setup

Note 3: Definition of Response time:

The response time is defined as the LCD optical switching time interval between “White” state and “Black” state. Rise time,  $T_r$ , is the time between photo detector output intensity changed from 90% to 10%. And fall time,  $T_f$ , is the time between photo detector output intensity changed from 10% to 90%



Note 4: Definition of contrast ratio:

The contrast ratio is defined as the following expression.

$$\text{Contrast ratio (CR)} = \frac{\text{Luminance measured when LCD on the "White" state}}{\text{Luminance measured when LCD on the "Black" state}}$$

Note 5: White  $V_i = V_{i50} \pm 1.5V$

Black  $V_i = V_{i50} \pm 2.0V$

“±” means that the analog input signal swings in phase with VCOM signal.

“±” means that the analog input signal swings out of phase with VCOM signal.

The 100% transmission is defined as the transmission of LCD panel when all the input terminals of module are electrically opened.

Note 6: Definition of color chromaticity (CIE 1931)

Color coordinates measured at the center point of LCD

Note 7: Measured at the center area of the panel when all the input terminals of LCD panel are electrically opened.

# 9.Interface

## 9.1. LCM PIN Definition

Pin	Symbol	Function	Remark
1	LED-	Power for LED backlight cathode	
2	LED-	Power for LED backlight cathode	
3	LED+	Power for LED backlight anode	
4	LED+	Power for LED backlight anode	
5	NC	No connect	
6	NC	No connect	
7	NC	No connect	
8	/RESET	Hardware reset	
9	SPENA	Chip select pin of serial interface	
10	SPCLK	Clock pin of serial interface	
11	SPDAT	Data input pin in serial mode	
12	B0	Data bus	
13	B1	Data bus	
14	B2	Data bus	
15	B3	Data bus	
16	B4	Data bus	
17	B5	Data bus	
18	B6	Data bus	
19	B7	Data bus	
20	G0	Data bus	
21	G1	Data bus	
22	G2	Data bus	
23	G3	Data bus	
24	G4	Data bus	
25	G5	Data bus	
26	G6	Data bus	
27	G7	Data bus	
28	R0	Data bus	
29	R1	Data bus	
30	R2	Data bus	
31	R3	Data bus	
32	R4	Data bus	
33	R5	Data bus	
34	R6	Data bus	
35	R7	Data bus	
36	HSYNC	Line synchronization signal	
37	VSYNC	Frame synchronization signal	
38	DCLK	Dot-clock signal and oscillator source	
39	NC	No connect	
40	NC	No connect	
41	VCC	Power Supply	
42	VCC	Power Supply	
43	NC	No connect	
44	NC	No connect	

45	NC	No connect	
46	NC	No connect	
47	NC	No connect	
48	SEL2	Input pin to select input interface mode	
49	SEL1	Input pin to select input interface mode	
50	SEL0	Input pin to select input interface mode	
51	NC	No connect	
52	DE	Display enable pin from controller. Internal pull high Connect to VDDIO or floating if not used	
53	DGND	System ground pin of the IC. Connect to system ground.	
54	AVSS	Grounding for analog circuit -Connect to system ground	

Note:

1. The mode control (SEL2) not use, it can't control CCIR601 interface, If not use CCIR601, it can floating.
2. For digital RGB input data format, both SYNC mode and DE+SYNC mode are supported. If DE signal is fixed low, SYNC mode is used. Otherwise, DE+SYNC mode is used. Suggest used SYNC mode!!\_
3. Usually pull high.\_
4. IF select serial RGB or CCIR601/656 input mode is selected, only DX0-DX7 used, and the other short to GND, Only selected serial RGB\_CCIR601/656 interface, DX BUS will enable, Digital input mode DX0 is LSB and DX7 is MSB.
5. Control the input data format

SEL2	SEL1	SEL0	Format	Operating Frequency
0	0	0	Parallel-RGB data format (only support stripe type color filter)	6.5MHZ
0	0	1	Serial-RGB data format	19.5 MHZ
0	1	0	CCIR 656data format (640RGB)	24.54 MHZ
0	1	1	CCIR 656data format (720RGB)	27 MHZ
1	0	0	YUV mode A data format(Cr-Y-Cb-Y)	24.54 MHZ
1	0	1	YUV mode A data format(Cr-Y-Cb-Y)	27 MHZ
1	1	0	YUV mode B data format(Cr-Y-Cr-Y)	27 MHZ
1	1	1	YUV mode B data format(Cr-Y-Cr-Y)	24.54 MHZ

Input format	DOTCLK Ferg(MHz)	Display Data	Active Area (DOTCLK)
YUV mode	24.54	640	1280
	27	720	1440

Mode	D[23:16]	D[15:8]	D[7:0]	IHS	IVS	DEN
ITU-R BT 656	D[23:16]	GND	GND	NC	NC	NC
ITU-R BT 601	D[23:16]	GND	GND	IHS	IVS	NC
8 bit RGB	D[23:16]	GND	GND	IHS	IVS	NC for HV Mode
						DEN for DEN Mode
24 bit RGB	R[7:0]	G[7:0]	B[7:0]	IHS	IVS	NC for HV Mode
						DEN for DEN Mode

## 9.2. SPI timing Characteristics

Parameter	Symbol	Min.	Typ.	Max.	Unit
SPCK period	Tcx	60	-	-	ns
SPCK high width	Tcxh	30	-	-	ns
SPCK low width	Tcxl	30	-	-	ns
Data setup time	Tsu1	12	-	-	ns
Data hold time	Thd1	12	-	-	ns
SPENA to SPCK setup time	Tcs	20	-	-	ns
SPENA to SPDA hold time	Tce	20	-	-	ns
SPENA high pulse width	Tcd	50	-	-	ns
SPDA output latency	Tcs	-	1/2	-	Tcx

### ● SPI read timing

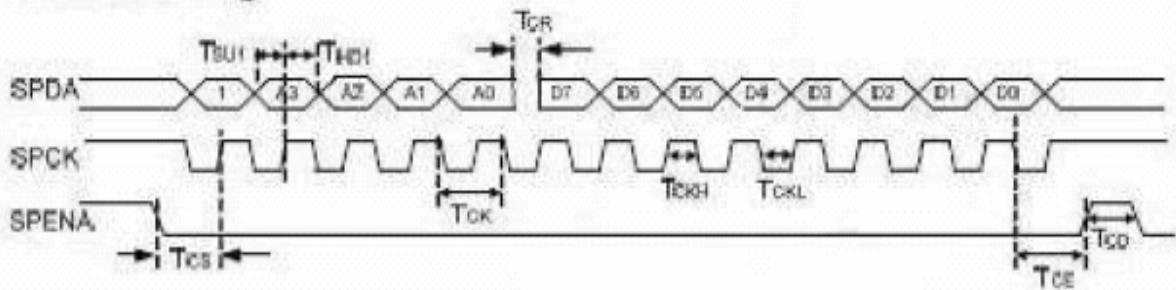

### ● SPI write timing

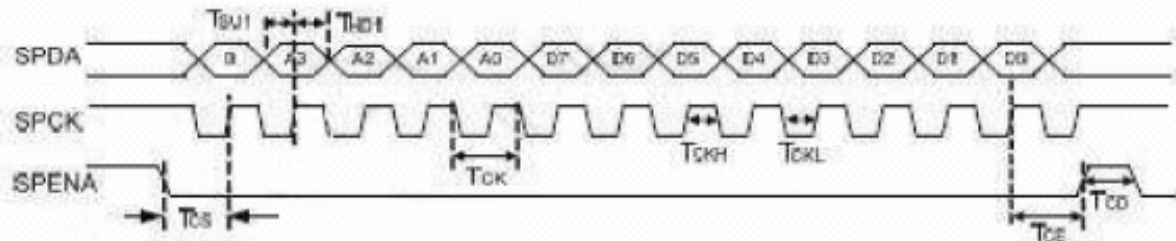

Figure11 SPI read and write timing

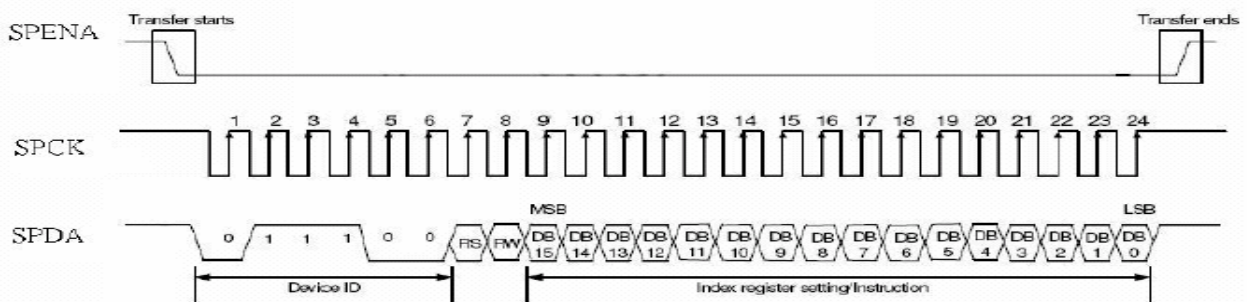

Figure12 SPI timing

### 9.3. Basic Display Color and Gray Scale

Color		Input Color Data																							
		Red								Green								Blue							
		MSB				LSB				MSB				LSB				MSB				LSB			
		R7	R6	R5	R4	R3	R2	R1	R0	G7	G6	G5	G4	G3	G2	G1	G0	B7	B6	B5	B4	B3	B2	B1	B0
Basic Colors	Black	0	0	0	0	0	0	0	0	0	0	0	0	0	0	0	0	0	0	0	0	0	0	0	0
	Red(255)	1	1	1	1	1	1	1	1	0	0	0	0	0	0	0	0	0	0	0	0	0	0	0	0
	Green(255)	0	0	0	0	0	0	0	0	1	1	1	1	1	1	1	1	0	0	0	0	0	0	0	0
	Blue(255)	0	0	0	0	0	0	0	0	0	0	0	0	0	0	0	0	1	1	1	1	1	1	1	1
	Cyan	0	0	0	0	0	0	0	0	1	1	1	1	1	1	1	1	1	1	1	1	1	1	1	1
	Magenta	1	1	1	1	1	1	1	1	0	0	0	0	0	0	0	0	1	1	1	1	1	1	1	1
	Yellow	1	1	1	1	1	1	1	1	1	1	1	1	1	1	1	1	0	0	0	0	0	0	0	0
	White	1	1	1	1	1	1	1	1	1	1	1	1	1	1	1	1	1	1	1	1	1	1	1	1
Red	Red(0) Dark	0	0	0	0	0	0	0	0	0	0	0	0	0	0	0	0	0	0	0	0	0	0	0	0
	Red(1)	0	0	0	0	0	0	0	1	0	0	0	0	0	0	0	0	0	0	0	0	0	0	0	0
	Red(2)	0	0	0	0	0	0	1	0	0	0	0	0	0	0	0	0	0	0	0	0	0	0	0	0
	:	:	:	:	:	:	:	:	:	:	:	:	:	:	:	:	:	:	:	:	:	:	:	:	:
	Red(253)	1	1	1	1	1	1	0	1	0	0	0	0	0	0	0	0	0	0	0	0	0	0	0	0
	Red(254)	1	1	1	1	1	1	1	0	0	0	0	0	0	0	0	0	0	0	0	0	0	0	0	0
	Red(255) Bright	1	1	1	1	1	1	1	1	0	0	0	0	0	0	0	0	0	0	0	0	0	0	0	0
Green	Green(0) Dark	0	0	0	0	0	0	0	0	0	0	0	0	0	0	0	0	0	0	0	0	0	0	0	0
	Green(1)	0	0	0	0	0	0	0	0	0	0	0	0	0	0	1	0	0	0	0	0	0	0	0	
	Green(2)	0	0	0	0	0	0	0	0	0	0	0	0	0	1	0	0	0	0	0	0	0	0	0	
	:	:	:	:	:	:	:	:	:	:	:	:	:	:	:	:	:	:	:	:	:	:	:	:	
	Green(253)	0	0	0	0	0	0	0	1	1	1	1	1	1	1	0	1	0	0	0	0	0	0	0	
	Green(254)	0	0	0	0	0	0	0	1	1	1	1	1	1	1	1	0	0	0	0	0	0	0	0	
	Green(255) Bright	0	0	0	0	0	0	0	1	1	1	1	1	1	1	1	1	0	0	0	0	0	0	0	
Blue	Blue(0) Dark	0	0	0	0	0	0	0	0	0	0	0	0	0	0	0	0	0	0	0	0	0	0	0	0
	Blue(1)	0	0	0	0	0	0	0	0	0	0	0	0	0	0	0	0	0	0	0	0	0	0	0	1
	Blue(2)	0	0	0	0	0	0	0	0	0	0	0	0	0	0	0	0	0	0	0	0	0	0	1	0
	:	:	:	:	:	:	:	:	:	:	:	:	:	:	:	:	:	:	:	:	:	:	:	:	
	Blue(253)	0	0	0	0	0	0	0	0	0	0	0	0	0	0	0	0	1	1	1	1	1	1	0	1
	Blue(254)	0	0	0	0	0	0	0	0	0	0	0	0	0	0	0	0	1	1	1	1	1	1	1	0
	Blue(255) Bright	0	0	0	0	0	0	0	0	0	0	0	0	0	0	0	0	1	1	1	1	1	1	1	1



# 10. Block Diagram

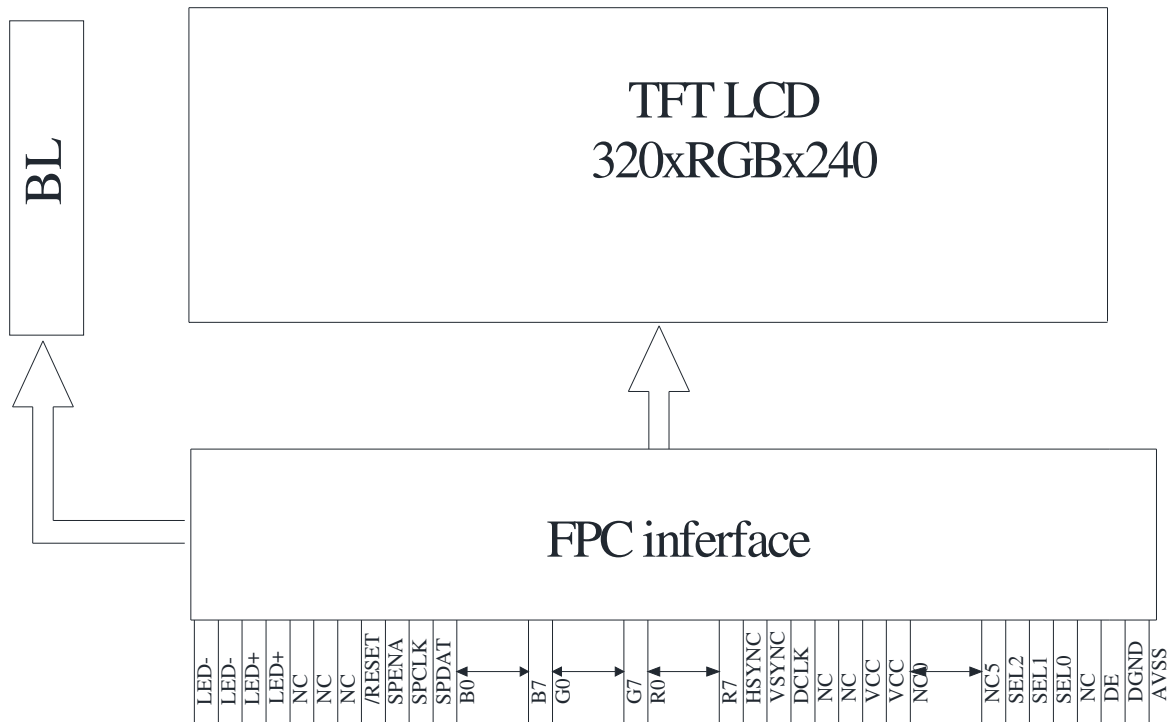

# 11. Reliability

Content of Reliability Test (Wide temperature, -20°C ~70°C)

Environmental Test			
Test Item	Content of Test	Test Condition	Note
High Temperature storage	Endurance test applying the high storage temperature for a long time.	80°C 200hrs	2
Low Temperature storage	Endurance test applying the low storage temperature for a long time.	-30°C 200hrs	1,2
High Temperature Operation	Endurance test applying the electric stress (Voltage & Current) and the thermal stress to the element for a long time.	70°C 200hrs	—
Low Temperature Operation	Endurance test applying the electric stress under low temperature for a long time.	-20°C 200hrs	1
High Temperature/ Humidity Operation	The module should be allowed to stand at 60 °C,90%RH max For 96hrs under no-load condition excluding the polarizer, Then taking it out and drying it at normal temperature.	60°C,90%RH 96hrs	1,2
Thermal shock resistance	The sample should be allowed stand the following 10 cycles of operation  <div style="text-align: center;"> <p style="text-align: center;">-20°C      25°C      70°C</p> <p style="text-align: center;"> <span style="display: inline-block; width: 100px; border-bottom: 1px solid black; margin-bottom: 5px;"></span> <span style="display: inline-block; width: 100px; border-bottom: 1px solid black; margin-bottom: 5px;"></span> </p> <p style="text-align: center;">30min    5min    30min</p> <p style="text-align: center;">1 cycle</p> </div>	-20°C/70°C 10 cycles	—
Vibration test	Endurance test applying the vibration during transportation and using.	Total fixed amplitude : 15mm Vibration Frequency : 10~55Hz One cycle 60 seconds to 3 directions of X,Y,Z for Each 15 minutes	3
Static electricity test	Endurance test applying the electric stress to the terminal.	C=150pF,R=330Ω,5point/panel Air:±8Kv,5times; Contact:±4Kv, 5times (Environment:15°C~35°C, 30%~60%.86Kpa~106Kpa)	—

Note1: No dew condensation to be observed.

Note2: The function test shall be conducted after 4 hours storage at the normal Temperature and humidity after remove from the test chamber.

Note3: The packing have to including into the vibration testing.

# 12. Contour Drawing

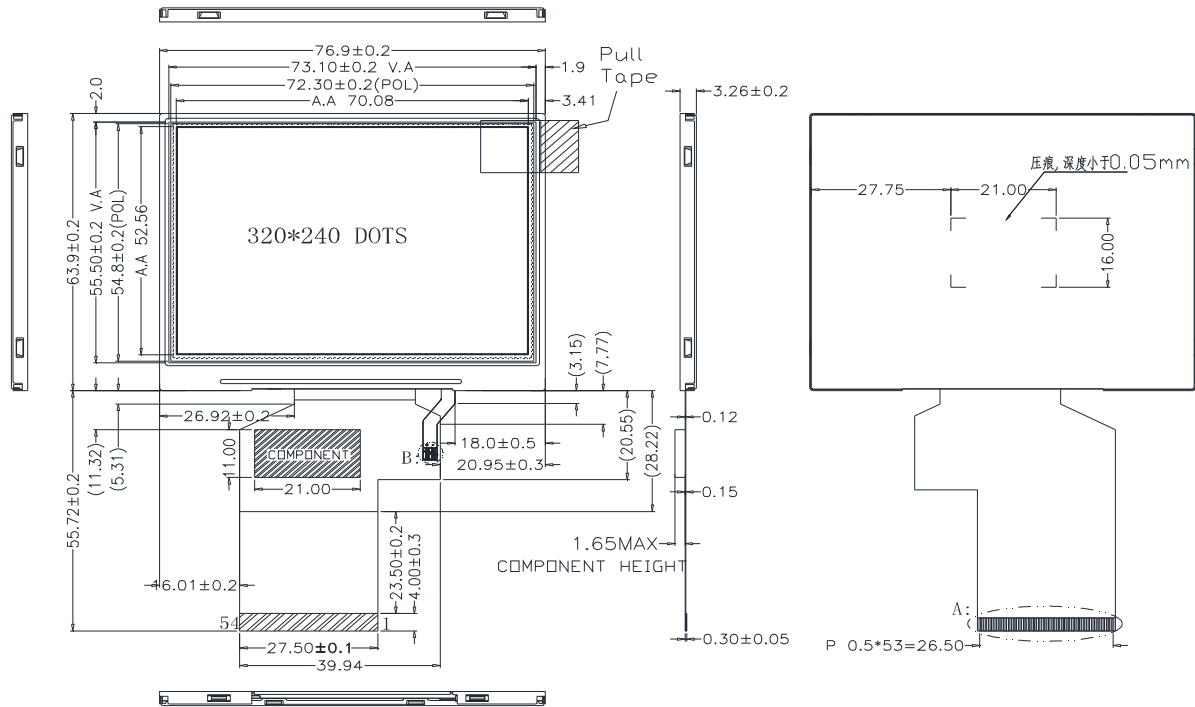

PIN NO.	SYMBOL	PIN NO.	SYMBOL
1	LED-	28	RO
2	LED-	29	R1
3	LED+	30	R2
4	LED+	31	R3
5	NC	32	R4
6	NC	33	R5
7	NC	34	R6
8	/RESET	35	R7
9	SPENA	36	HSYNC
10	SPCLK	37	VSYNC
11	SPDAT	38	DCLK
12	B0	39	NC
13	B1	40	NC
14	B2	41	VCC
15	B3	42	VCC
16	B4	43	NC
17	B5	44	NC
18	B6	45	NC
19	B7	46	NC
20	G0	47	NC
21	G1	48	SEL2
22	G2	49	SEL1
23	G3	50	SELO
24	G4	51	NC
25	G5	52	DE
26	G6	53	DGND
27	G7	54	AVSS

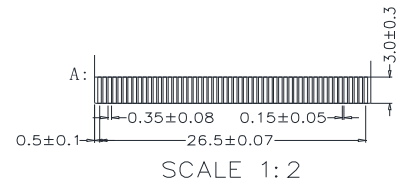
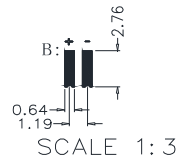
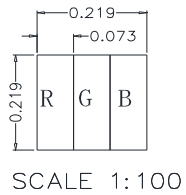

# 13.PACKAGE SPECIFICATION

<b>LCM Model</b>	WF35LTIACDNN0#	<b>LCM 包裝規格書</b> <b>LCM Packaging Specifications</b>	<b>Approve</b>	<b>Check</b>	<b>Contact</b>
<b>Drawing NO.</b>			<b>DATE</b>	初版	版次 Ver
			03/26/14'	03/26/14'	0
<b>1.包裝材料規格表 (Packaging Material) :(per carton)</b>					
NO.	Item	Model	Dimensions	Quantity	
1	成品 (LCM)	WF35LTIACDNN0#		216	
2	TRAY 盤 (2)	PKCA1XXXXXXXXXXXX0357	315*265mm	36	
3	BP01 內盒(3)Product Box	PK3Y1XXXXXXXXXXXX0001	332*280*100mm	6	
4	泡棉(4)Foam	-----	-	6	
5	外紙箱(5)Carton	PK4X1XXXXXXXXXXXX0000	565*340*320mm	1	
6					
7					
8					
9					
<b>2.單箱數量規格表(Packaging Specifications and Quantity) :</b>					
(1)LCM quantity per box : no per tray		6	x no of tray	6 =	36
(2)Total LCM quantity in carton : quantity per box		36	x no of boxes	6 =	216
<b>特 記 事 項 (REMARK)</b>					
1. Label Specifications :					
MOOEL: LOT NO : QUANTITY: CHECK:					

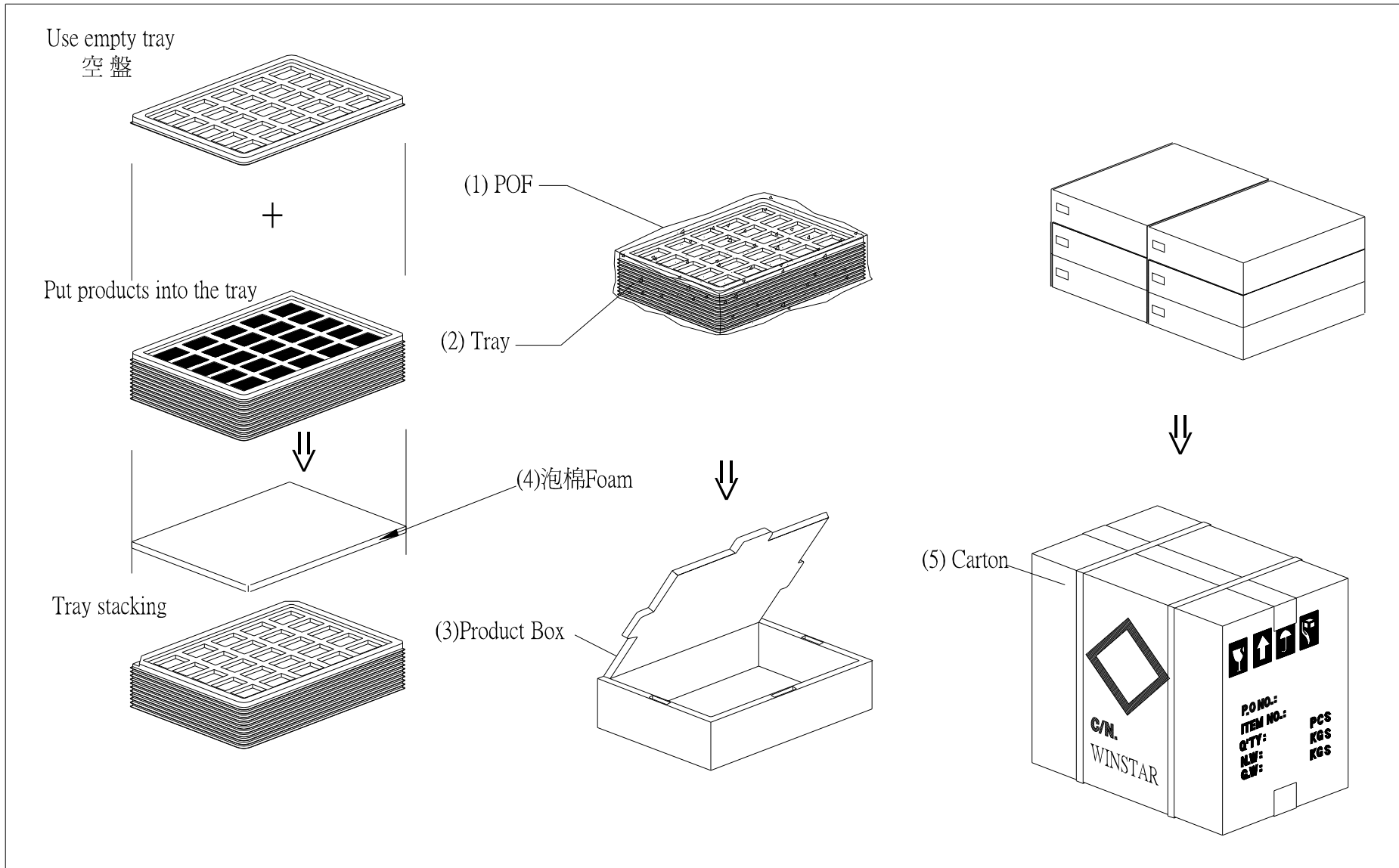



**1、Panel Specification :**

- 1. Panel Type :  Pass  NG , \_\_\_\_\_
- 2. View Direction :  Pass  NG , \_\_\_\_\_
- 3. Numbers of Dots :  Pass  NG , \_\_\_\_\_
- 4. View Area :  Pass  NG , \_\_\_\_\_
- 5. Active Area :  Pass  NG , \_\_\_\_\_
- 6. Operating Temperature :  Pass  NG , \_\_\_\_\_
- 7. Storage Temperature :  Pass  NG , \_\_\_\_\_
- 8. Others : \_\_\_\_\_

**2、Mechanical Specification :**

- 1. PCB Size :  Pass  NG , \_\_\_\_\_
- 2. Frame Size :  Pass  NG , \_\_\_\_\_
- 3. Material of Frame :  Pass  NG , \_\_\_\_\_
- 4. Connector Position :  Pass  NG , \_\_\_\_\_
- 5. Fix Hole Position :  Pass  NG , \_\_\_\_\_
- 6. Backlight Position :  Pass  NG , \_\_\_\_\_
- 7. Thickness of PCB :  Pass  NG , \_\_\_\_\_
- 8. Height of Frame to PCB :  Pass  NG , \_\_\_\_\_
- 9. Height of Module :  Pass  NG , \_\_\_\_\_
- 10. Others :  Pass  NG , \_\_\_\_\_

**3、Relative Hole Size :**

- 1. Pitch of Connector :  Pass  NG , \_\_\_\_\_
- 2. Hole size of Connector :  Pass  NG , \_\_\_\_\_
- 3. Mounting Hole size :  Pass  NG , \_\_\_\_\_
- 4. Mounting Hole Type :  Pass  NG , \_\_\_\_\_
- 5. Others :  Pass  NG , \_\_\_\_\_

**4、Backlight Specification :**

- 1. B/L Type :  Pass  NG , \_\_\_\_\_
- 2. B/L Color :  Pass  NG , \_\_\_\_\_
- 3. B/L Driving Voltage (Reference for LED Type) :  Pass  NG , \_\_\_\_\_
- 4. B/L Driving Current :  Pass  NG , \_\_\_\_\_
- 5. Brightness of B/L :  Pass  NG , \_\_\_\_\_
- 6. B/L Solder Method :  Pass  NG , \_\_\_\_\_
- 7. Others :  Pass  NG , \_\_\_\_\_

>> **Go to page 2** <<



Winstar      Module Number : \_\_\_\_\_

Page: 2

**5、Electronic Characteristics of Module :**

- |                              |                               |                               |       |
|------------------------------|-------------------------------|-------------------------------|-------|
| 1. Input Voltage :           | <input type="checkbox"/> Pass | <input type="checkbox"/> NG , | _____ |
| 2. Supply Current :          | <input type="checkbox"/> Pass | <input type="checkbox"/> NG , | _____ |
| 3. Driving Voltage for LCD : | <input type="checkbox"/> Pass | <input type="checkbox"/> NG , | _____ |
| 4. Contrast for LCD :        | <input type="checkbox"/> Pass | <input type="checkbox"/> NG , | _____ |
| 5. B/L Driving Method :      | <input type="checkbox"/> Pass | <input type="checkbox"/> NG , | _____ |
| 6. Negative Voltage Output : | <input type="checkbox"/> Pass | <input type="checkbox"/> NG , | _____ |
| 7. Interface Function :      | <input type="checkbox"/> Pass | <input type="checkbox"/> NG , | _____ |
| 8. LCD Uniformity :          | <input type="checkbox"/> Pass | <input type="checkbox"/> NG , | _____ |
| 9. ESD test :                | <input type="checkbox"/> Pass | <input type="checkbox"/> NG , | _____ |
| 10. Others :                 | <input type="checkbox"/> Pass | <input type="checkbox"/> NG , | _____ |

**6、Summary :**

Sales signature : \_\_\_\_\_

Customer Signature : \_\_\_\_\_

Date :      /      /      \_\_\_\_\_



a2zelectronic.com

Sourcing Simplified

